



POLAR

Makes life easy

The Coolest Fan Book



Over 50 years,

Polar has been at the forefront of innovation that simplifies everyday living.



We've mastered the art of making every home and workspace cooler and smarter while keeping sustainability and affordability at the core. As we continue to create products that resonate across generations, Polar remains the force that keeps every moment easy and every space alive. Year after year, each product and innovation brings us closer to one goal: making comfort an integral part of daily life.

BEAT THE HEAT WITH THE COOLEST OPTIONS

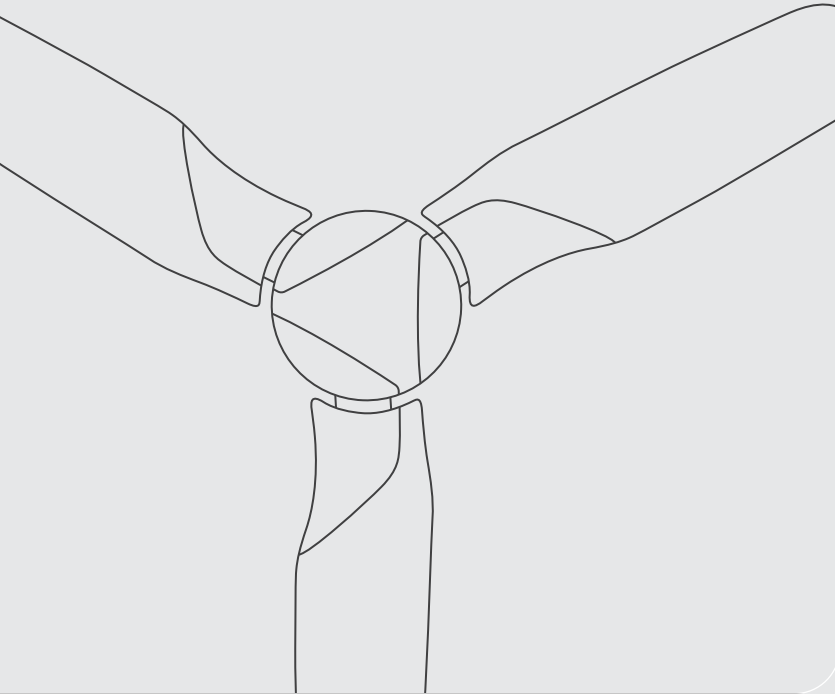

Want to save energy?

Best options are on pages

01 _____ 12

Want our signature comfort at home?

Choose from pages

13 _____ 48

Want to tackle heat smartly?

Choose from pages

49 _____ 90

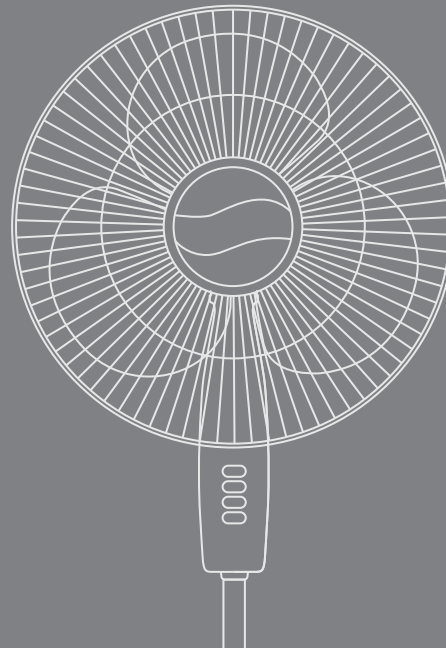

Small space?

Ideal options are on pages

91 _____ 100

If you want odourless indoors,

choose from pages

101 _____ 106

Make large spaces comfortable,

with options from pages

107 _____ 114

BLDC Fans

POWER UP

WITH SMART

SAVINGS



GOLDEN DUNE



RF Remote

WINLITE

Super Energy-saving Fan



POLAR WINLITE

3 YEARS WARRANTY

Features

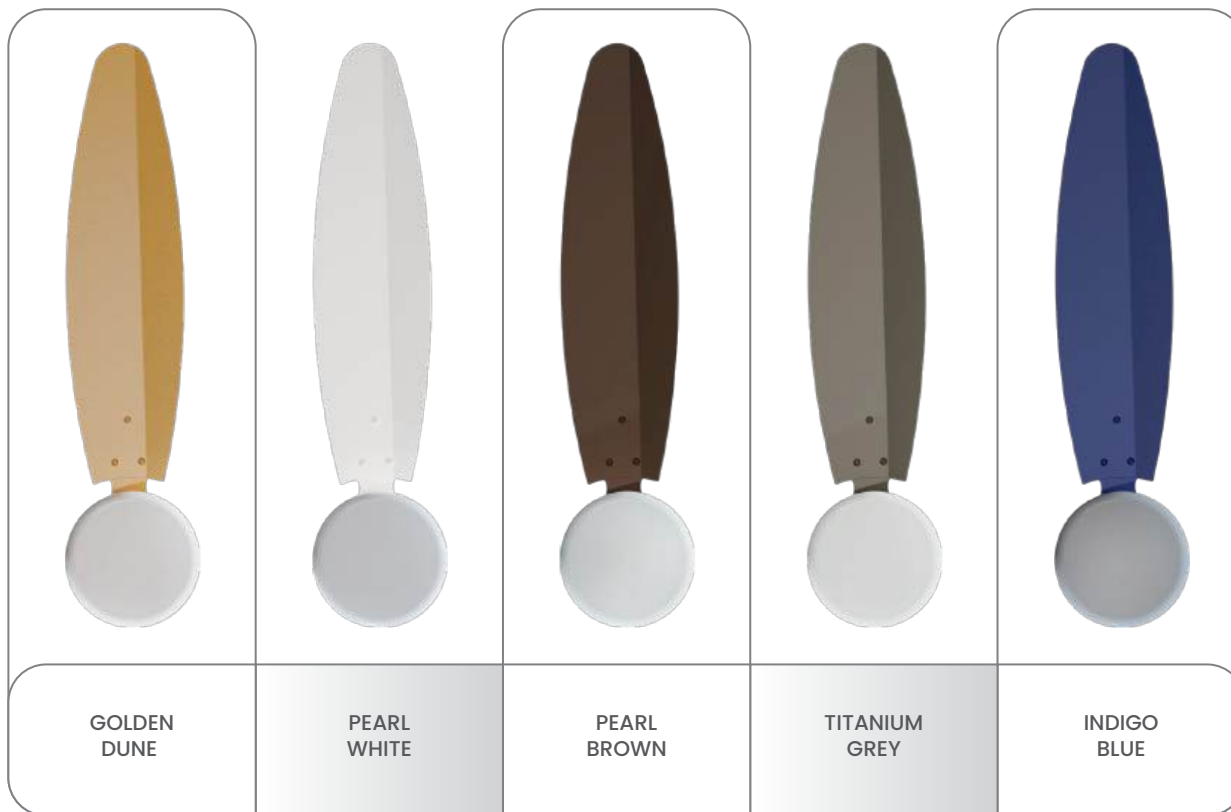

- Powerful 100% Copper BLDC motor with 60% power savings
- 3-tone LED underlight (warm, natural & cool) with adjustable brightness
- RF remote for convenient control from anywhere in the room
- Aerodynamically designed unique blades for high air thrust
- Reverse rotation for warm air circulation in Winters

- Sleep-well timer with auto shut-off (up to 8 hours)
- Wide operational voltage with fluctuation protection (150 V to 260 V)
- Booster mode for maximum airflow



Must not be connected through any external regulator.

TECHNICAL SPECIFICATIONS

Sweep in mm	Power Input in Watts	Speed in RPM	Air Delivery in CMM	Service Value in CMM/Watts
1200	32*	350	220	6.9

*with light – 38 W

**At lower speed, power consumption reduces substantially

GOLDEN DUNE

EFISLIM

Super Energy-saving Fan



IR Remote









POLAR EFISLIM

3 YEARS WARRANTY

Features



-  Powerful 100% Copper BLDC motor with 60% power savings
-  Remote controller for speed regulation
-  Sleep-well timer with auto shut-off (up to 8 hours)
-  Booster mode for maximum air-flow
-  Sleek design with LED indicator
-  Reverse rotation for warm air circulation in Winters

- Wide operational voltage with fluctuation protection (150 v to 260 v)
- Aerodynamic & slim design for higher air delivery



 Must not be connected through any external regulator.

TECHNICAL SPECIFICATIONS

Sweep in mm	Power Input in Watts	Speed in RPM	Air Delivery in CMM	Service Value in CMM/Watts
600	25	750	100	4.0
900	30	500	170	5.6
1200	32	350	225	7.0

**At lower speed, power consumption reduces substantially

ELEPHANT GREY

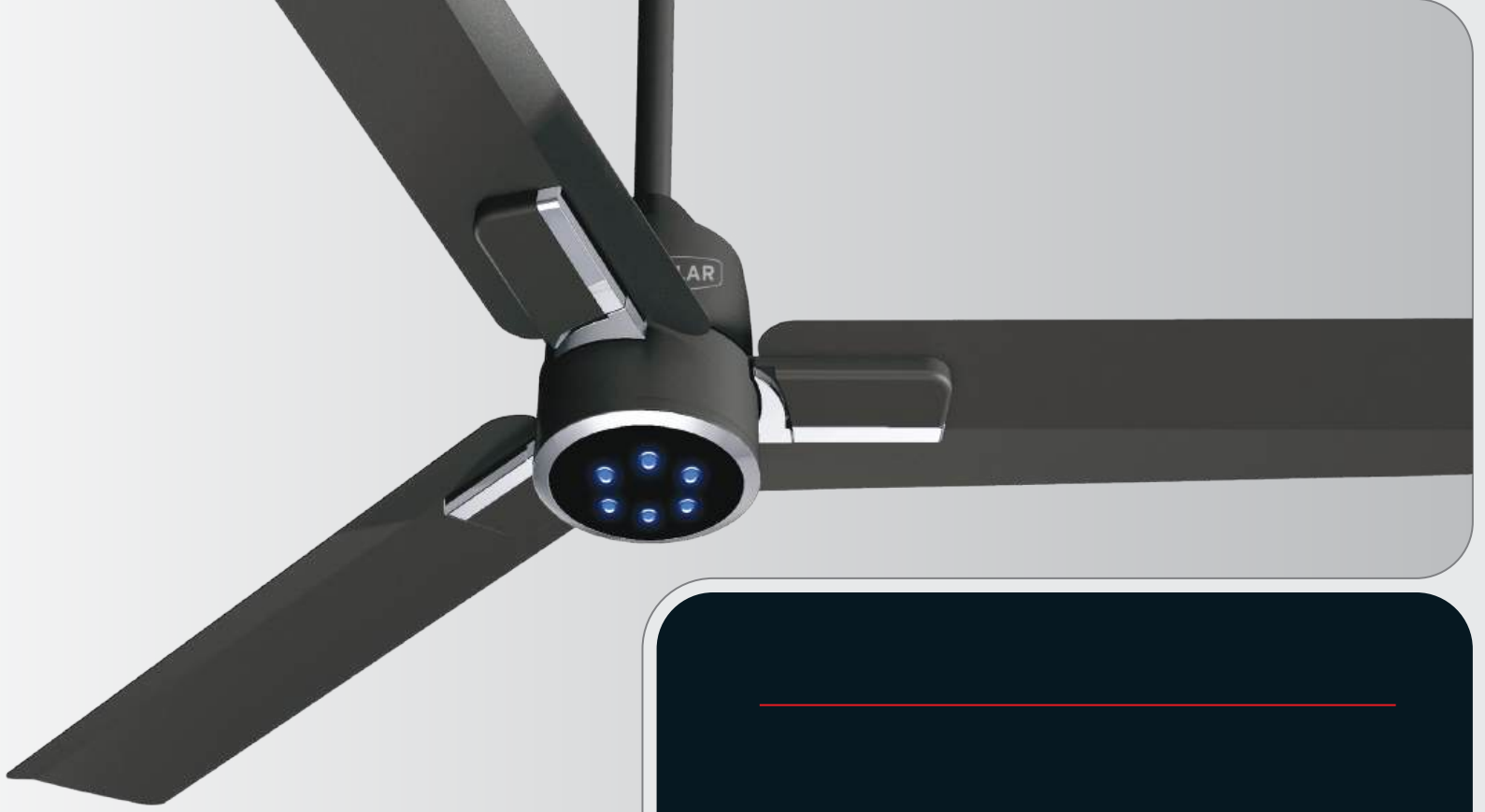

IR Remote

EFISLIM NEO

Super Energy-saving Fan



POLAR EFISLIM NEO

3 YEARS WARRANTY



COBALT BLUE



RUSTY COPPER

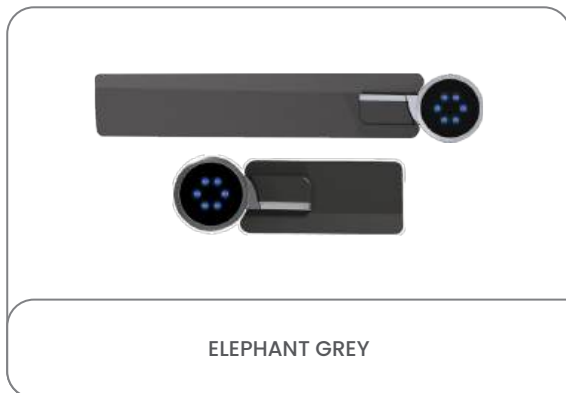

ELEPHANT GREY



GLOSSY BLACK

Features

-  Powerful BLDC motor with 60% power savings
-  Remote controller for speed regulation
-  Superior powder-coated paint for long-lasting attractive finish
-  Booster mode for maximum airflow
-  Sleek design with LED indicator
-  Reverse-rotation for warm air circulation in Winter.

- Wide operational voltage with fluctuation protection (150 V to 260 V)
- Aerodynamic & slim design for modern homes
- Sleep-well timer with auto shut-off (up to 8 hours)



 Must not be connected through any external regulator.

TECHNICAL SPECIFICATIONS

Sweep in mm	Power Input in Watts	Speed in RPM	Air Delivery in CMM	Service Value in CMM/Watts
600	25	750	100	4.0
900	30	500	170	5.6
1200	32	350	225	7.0

**At lower speed, power consumption reduces substantially

09

WHITE

EFICO

Super Energy-saving Fan



RF Remote



POLAR EFICO

2 YEARS WARRANTY

Features



BLDC motor with 65% power savings



High-performance long-life motor



Aerodynamically designed ribbed blades for high air thrust



RF remote for convenient control from anywhere in the room



BROWN

WHITE

IVORY

- Wide operational voltage with fluctuation protection (150 V to 260 V)



Must not be connected through any external regulator.

TECHNICAL SPECIFICATIONS

Sweep in mm
1200

Power Input in Watts
26

Speed in RPM
350

Air Delivery in CMM
210

Service Value in CMM/Watts
8.0

**At lower speed, power consumption reduces substantially

IVORY



PS-32

Super Energy-saving Fan



POLAR PS-32

2 YEARS WARRANTY

Features



BLDC motor with 60% power savings



220 CMM for high air delivery



Remote controller for speed regulation



Wider blade tips for high air thrust and spread



BROWN

WHITE

IVORY

SMOKE BROWN

- Wide operational voltage with fluctuation protection (150 V to 260 V)



Must not be connected through any external regulator.

TECHNICAL SPECIFICATIONS

Sweep in mm	Power Input in Watts	Speed in RPM	Air Delivery in CMM	Service Value in CMM/Watts
1200	32	350	220	6.8

**At lower speed, power consumption reduces substantially

Signature Fans

AN ICONIC
SPIN ON
COMFORT

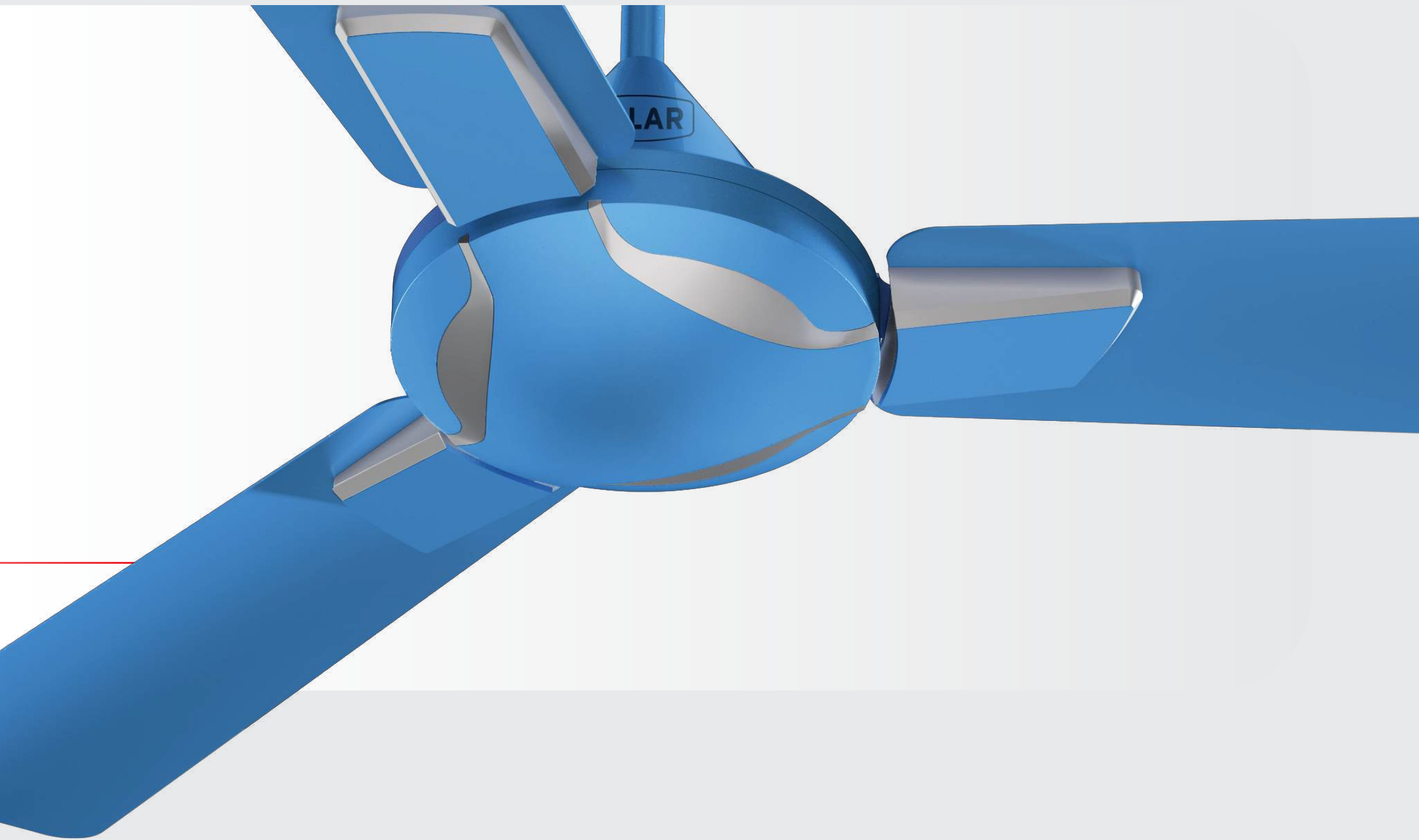



TOPAZ

EFISAVY ANTI-DUST

Energy-saving Fan



POLAR EFISAVY ANTI-DUST

3 YEARS WARRANTY

Features



-  Powerful & energy-efficient 100% Copper motor
-  220 CMM for wider air spread & high thrust
-  Wide range of lustrous metallic paints to suit every style
-  Wide Aluminium blades for high air delivery
-  Anti-dust coating to ensure minimal dust deposition & easy cleaning

- Contemporary designer fans that are energy-efficient



TECHNICAL SPECIFICATIONS

Sweep in mm	Power Input in Watts	Speed in RPM	Air Delivery in CMM	Service Value in CMM/Watts
1200	48	360	220	4.5

IVORY

POLAR

WINSPIN

Energy-saving Fan



POLAR WINSPIN

2 YEARS WARRANTY

Features



Powerful & energy-efficient
100% Copper motor



Wide Aluminium blades for high air thrust



GOLDEN DUNE

BAKER BROWN

SMOKE BROWN

IVORY

- Aesthetically designed decorative ring and blade trims

TECHNICAL SPECIFICATIONS

Sweep
in mm
900
1200

Power Input
in Watts
36
48

Speed
in RPM
450
360

Air Delivery
in CMM
130
220

Service Value
in CMM/Watts
3.6
4.5





MATT SILVER

SUPER SPEED

Energy-saving Fan



POLAR SUPER SPEED

4 YEARS WARRANTY

Features



220 CMM for high air delivery



Powerful & energy-efficient 100% Copper motor



Wider blade tips for excellent air delivery and thrust



Aluminium construction blades & body made of high-grade Aluminium



MATT IVORY

MATT SILVER

MATT BROWN

MATT WHITE

- Minimalist design for modern homes



TECHNICAL SPECIFICATIONS

Sweep in mm
1200

Power Input in Watts
48

Speed in RPM
360

Air Delivery in CMM
220

Service Value in CMM/Watts
4.5

WHITE

36 SUPER SPEED

Energy-saving Fan



POLAR 36 SUPER SPEED

2 YEARS WARRANTY

Features



600 RPM for super high-speed



Powerful and energy-efficient robust motor



Wide Aluminium blades for high air thrust



BROWN



IVORY



WHITE

- Powder coated for longer life



TECHNICAL SPECIFICATIONS

Sweep in mm
900

Power Input in Watts
48

Speed in RPM
600

Air Delivery in CMM
173

Service Value in CMM/Watts
3.6



IVORY

24 SUPER SPEED

Energy-saving Fan



POLAR 24 SUPER SPEED

2 YEARS WARRANTY

Features



840 RPM for super high-speed



Powerful & energy-efficient 100% Copper motor



Powder coated for longer life



Elegant & compact design for small rooms & kitchens

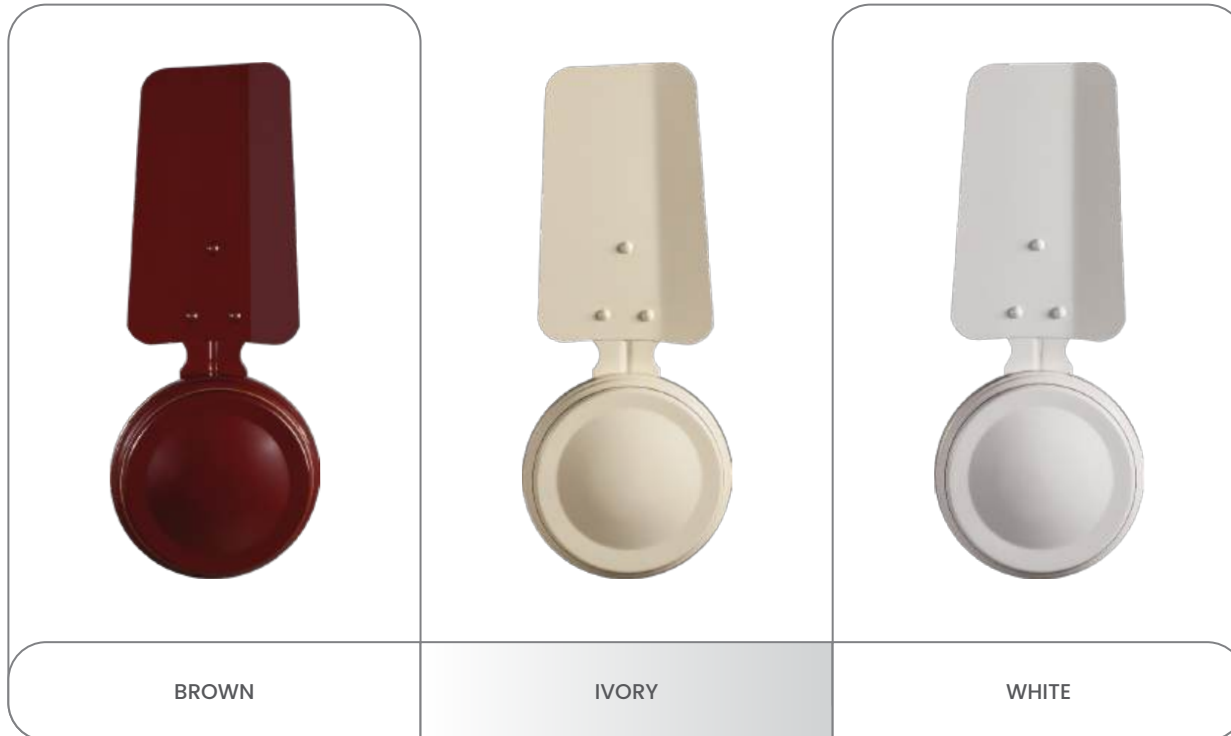

BROWN

IVORY

WHITE

- Four-bladed fan with high air thrust
- Ideal for small spaces like puja rooms, bathrooms, kitchens, cabins, shops, etc.

TECHNICAL SPECIFICATIONS

Sweep in mm
600

Power Input in Watts
55

Speed in RPM
840

Air Delivery in CMM
110

Service Value in CMM/Watts
2.0



IVORY (DECO MODEL)



WINPRO





Energy-saving Fan



POLAR WINPRO

4 YEARS WARRANTY

Features

-  Powerful & energy-efficient 100% Copper motor
-  Wide Aluminium blades for high air thrust
-  Deco model with super elegant two-part blade trims
-  220 CMM for wider air spread and high thrust



BROWN (DECO MODEL)

BROWN (BASE MODEL)

IVORY (DECO MODEL)

IVORY (BASE MODEL)

WHITE (DECO MODEL)

WHITE (BASE MODEL)

- All-time favourite fan



TECHNICAL SPECIFICATIONS

Sweep in mm
1200

Power Input in Watts
48

Speed in RPM
360

Air Delivery in CMM
220

Service Value in CMM/Watts
4.5



BROWN

WINPRO NEO

Energy-saving Fan



POLAR WINPRO NEO

4 YEARS WARRANTY

Features



Powerful and energy-efficient robust motor



Wide Aluminium blades for high air thrust



220 CMM for wider air spread and high thrust



BROWN



IVORY



WHITE

- All-time favourite fan



TECHNICAL SPECIFICATIONS

Sweep in mm
1200

Power Input in Watts
48

Speed in RPM
360

Air Delivery in CMM
220

Service Value in CMM/Watts
4.5

TOPAZ



WINSTYLE

Energy-saving Fan



POLAR WINSTYLE

2 YEARS WARRANTY

Features



Powerful & energy-efficient
100% Copper motor



Wide and aerodynamically designed blades for high air thrust



High-speed
400 RPM



PEARL BROWN

IVORY

SMOKE BROWN

TOPAZ

- Aesthetically designed decorative ring and blade trims

TECHNICAL SPECIFICATIONS

Sweep
in mm
1200

Power Input
in Watts
46

Speed
in RPM
400

Air Delivery
in CMM
210

Service Value
in CMM/Watts
4.5





RUSTY COPPER

RADIANT

Energy-saving Fan



POLAR RADIANT

2 YEARS WARRANTY

Features



Powerful & energy-efficient motor



Unique ribbed blades for high air thrust



Decorative annular motor ring and contemporary blade trims

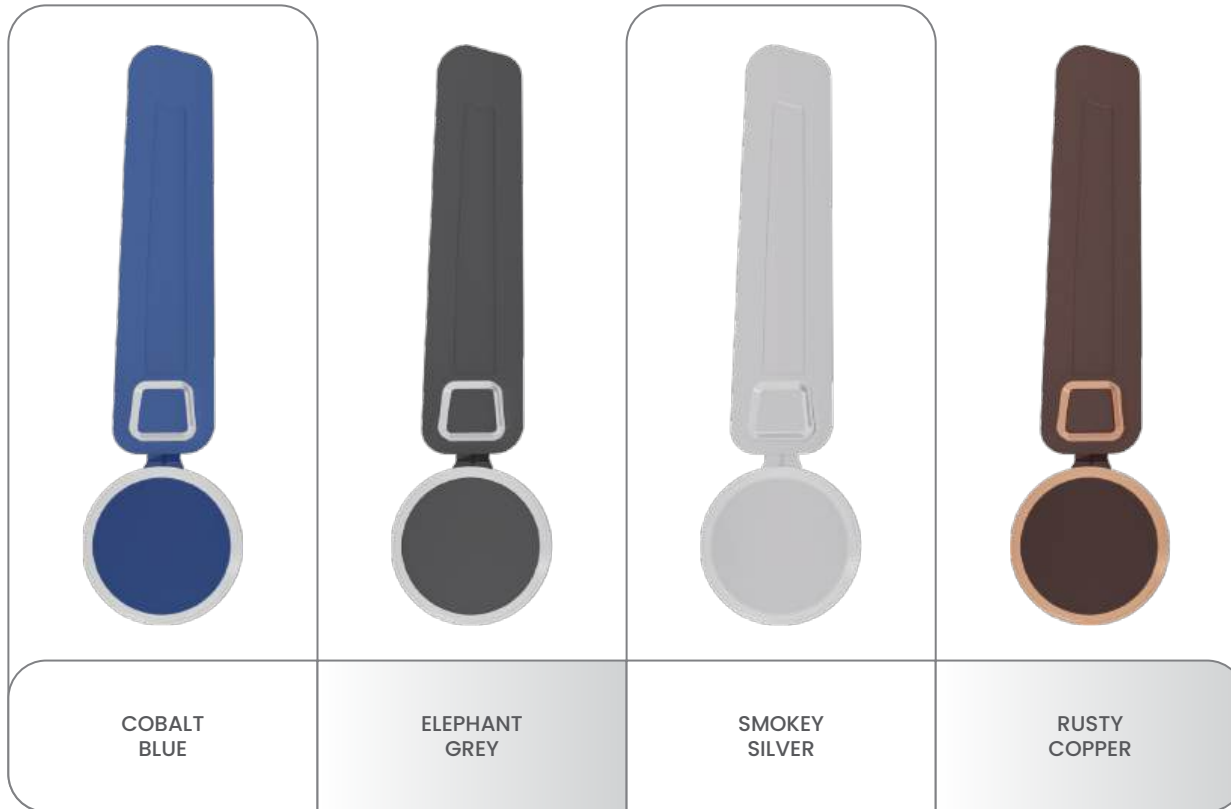

COBALT BLUE

ELEPHANT GREY

SMOKEY SILVER

RUSTY COPPER

- Refreshing design in a range of colours

TECHNICAL SPECIFICATIONS

Sweep
in mm
900
1200

Power Input
in Watts
36
46

Speed
in RPM
450
360

Air Delivery
in CMM
130
210

Service Value
in CMM/Watts
3.6
4.5



WHITE



WINDCHILL

Energy-saving Fan



POLAR WINDCHILL

2 YEARS WARRANTY

Features



Powerful & energy-efficient motor



Powder-coated for longer life



Aerodynamically designed ribbed blades for high air thrust



COBALT BLUE

RUSTY COPPER

SMOKE BROWN

ELEPHANT GREY

WHITE

- Attractive colour range to elevate the style quotient of any home

TECHNICAL SPECIFICATIONS

Sweep in mm
1200

Power Input in Watts
46

Speed in RPM
360

Air Delivery in CMM
210

Service Value in CMM/Watts
4.5



GLOSSY BLACK



VINDURA

Energy-saving Fan



POLAR VINDURA

2 YEARS WARRANTY

Features



Powerful & energy-efficient motor



Unique ribbed blades for high air thrust



Decorative annular motor ring and contemporary blade trims



SMOKE BROWN

RUSTY COPPER

COBALT BLUE

IVORY

GLOSSY BLACK

- Wide range of colours for stylish & modern homes

TECHNICAL SPECIFICATIONS

Sweep in mm
1200

Power Input in Watts
46

Speed in RPM
360

Air Delivery in CMM
210

Service Value in CMM/Watts
4.5



WHITE



TRENDY

Energy-saving Fan



POLAR TRENDY

2 YEARS WARRANTY

Features



Powerful and energy-efficient motor



Wide and aerodynamically designed blades for high air thrust



Powder-coated for longer life



SMOKE BROWN

COBALT BLUE

RUSTY COPPER

WHITE

- Robust fan with excellent performance
- Aesthetically designed decorative blade trims & showcap

TECHNICAL SPECIFICATIONS

Sweep in mm	Power Input in Watts	Speed in RPM	Air Delivery in CMM	Service Value in CMM/Watts
1200	46	360	210	4.5





IVORY

POWER SPEED

Energy-saving Fan



POLAR POWER SPEED

2 YEARS WARRANTY

Features



Powerful & energy-efficient
100% Copper motor



Scientifically ribbed blades for high air delivery and durability



High-speed with 400 RPM



BROWN

IVORY

WHITE

- Powder-coated for longer life

TECHNICAL SPECIFICATIONS

Sweep in mm	Power Input in Watts	Speed in RPM	Air Delivery in CMM	Service Value in CMM/Watts
1200	46	400	210	4.5



BROWN (DECO MODEL)



MEGAMITE

Energy-saving Fan



POLAR MEGAMITE

2 YEARS WARRANTY

Features



Powerful & energy-efficient
100% Copper motor



Scientifically ribbed blades for high air delivery and durability

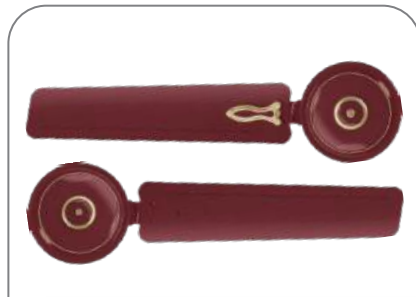

BROWN
(DECO & BASE MODEL)



IVORY
(DECO & BASE MODEL)

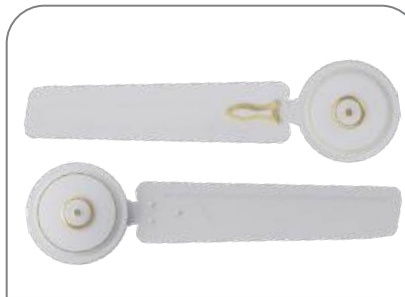

WHITE
(DECO & BASE MODEL)

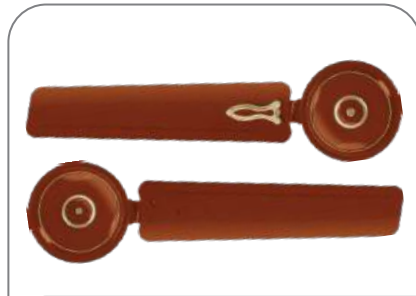

MATT BROWN
(DECO & BASE MODEL)



SMOKE BROWN
(DECO & BASE MODEL)



BROWN
(600 MM)

- Powder-coated for longer life
- Deco model with two-part decorative blade trims for an enhanced look (available in 900 mm and 1200 mm sweep)

TECHNICAL SPECIFICATIONS

Sweep in mm	Power Input in Watts	Speed in RPM	Air Delivery in CMM	Service Value in CMM/Watts
600	55	840	110	2.0
900	36	450	130	3.6
1200	46	400	210	4.5
1400	54	300	245	4.5





IVORY

MEGAMITE NEO

Energy-saving Fan



POLAR MEGAMITE NEO

2 YEARS WARRANTY

Features



Powerful and energy-efficient motor



Scientifically ribbed blades for high air delivery and durability



- Powder-coated for longer life

TECHNICAL SPECIFICATIONS

Sweep in mm	Power Input in Watts	Speed in RPM	Air Delivery in CMM	Service Value in CMM/Watts
600	55	840	110	2.0
900	36	450	130	3.6
1200	46	400	210	4.5
1400	54	300	245	4.5



45

BROWN

PAZERO

Energy-saving Fan



POLAR PAZERO

2 YEARS WARRANTY

Features



Powerful and energy-efficient 100% Copper motor



Aerodynamically designed ribbed blades



BROWN



IVORY



WHITE

- Powder-coated for longer life



TECHNICAL SPECIFICATIONS

Sweep in mm
1200

Power Input in Watts
46

Speed in RPM
400

Air Delivery in CMM
210

Service Value in CMM/Watts
4.5



WHITE

WINCHESTER

Energy-saving Fan



POLAR WINCHESTER

2 YEARS WARRANTY

Features



Powerful & energy-efficient motor



Aerodynamically designed ribbed blades



BROWN



IVORY



WHITE



BROWN
(600 MM-4 Blades)

- Powder-coated for longer life



TECHNICAL SPECIFICATIONS

Sweep in mm	Power Input in Watts	Speed in RPM	Air Delivery in CMM	Service Value in CMM/Watts
600	55	840	110	2.0
900	36	450	130	3.6
1200	46	400	210	4.5

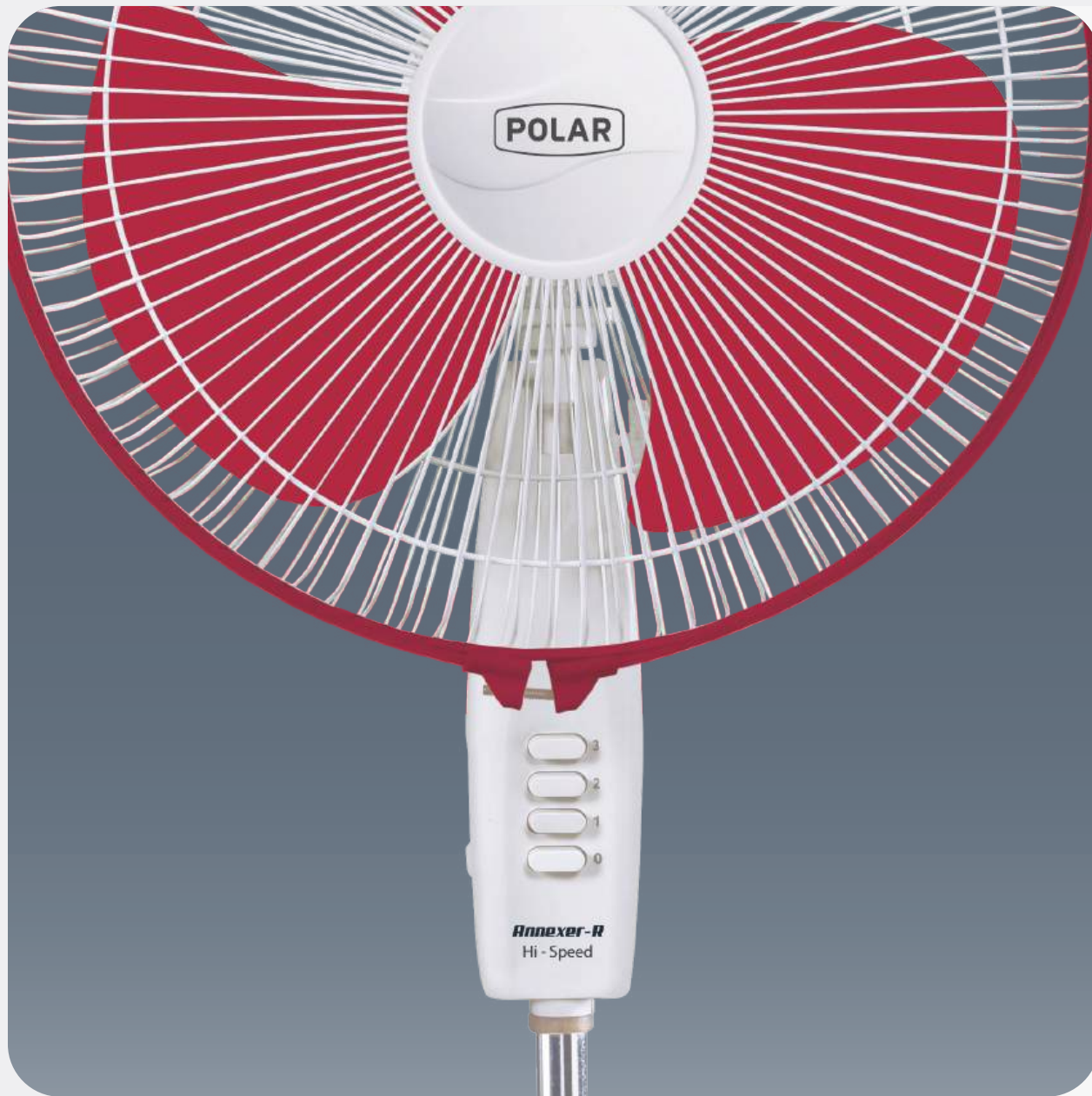

EXCEPTIONALLY
INNOVATIVE

TPW Fans

ANTIQUE BRONZE



GUSTY

Osc. Pedestal Fan









POLAR GUSTY

2 YEARS WARRANTY



ANTIQUE BRONZE

Features

-  Powerful and energy-efficient 100% Copper motor
-  Autothermal overload protection device for motor
-  Smooth 90-degree oscillation
-  Strong and large metal base for better stability
-  Aerodynamically designed 4-leaf Aluminium blades for higher air thrust & delivery
-  3-level speed control rotary switch

- Telescopic arrangement for height adjustment
- Lucrative smooth Bronze finish
- Upward & downward tilt mechanism

TECHNICAL SPECIFICATIONS

Sweep
in mm
400

Power Input
in Watts
65

Speed
in RPM
1350

Air Delivery
in CMM
72

BLACK-SILVER

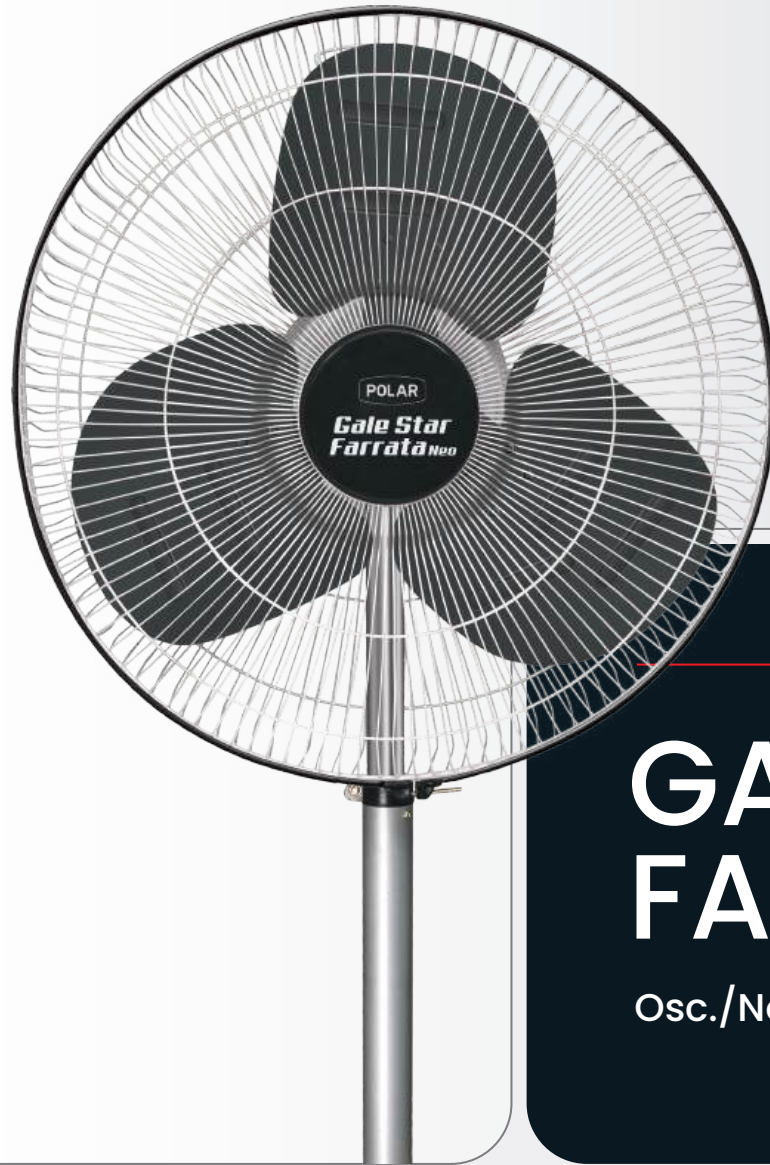

GALESTAR FARRATA

Osc./Non-osc. Pedestal Fan





POLAR GALESTAR FARRATA

2 YEARS WARRANTY

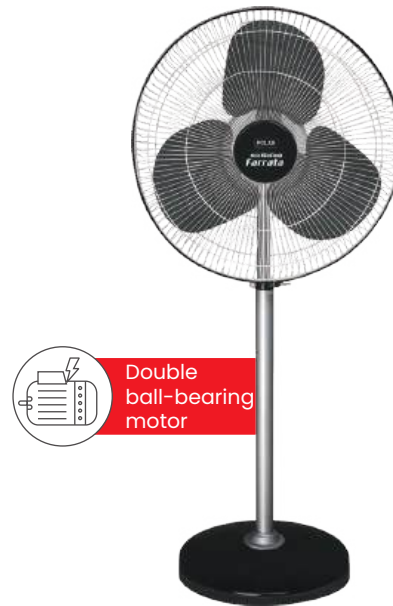
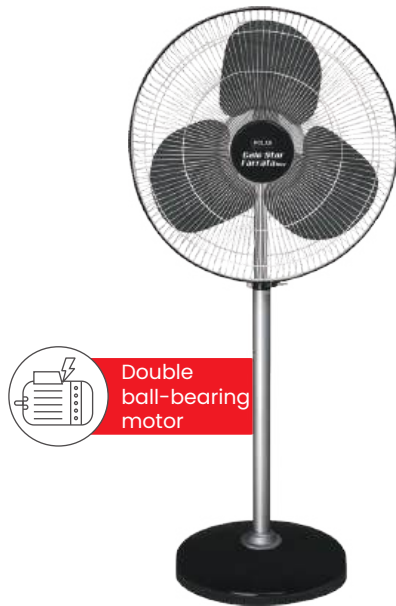
Features



 Double ball-bearing motor for better energy-efficiency & durability

 Aerodynamically designed, well-balanced metal blades for excellent air delivery

 Vibration-free operation

 Heavy and large base for better stability

 Telescopic arrangement for height adjustment

 Off+3-level speed control rotary switch

GALESTAR FARRATA NEO
BLACK-SILVER

GALESTAR OSCILLATING FARRATA
BLACK-SILVER

- Powder-coated finish for 100% corrosion resistance and durability for longer life
- Available in oscillating and non-oscillating models

TECHNICAL SPECIFICATIONS

Sweep
in mm
500

Power Input
in Watts
140

Speed
in RPM
1400

Air Delivery
in CMM
120

BLACK-CHROME

BLUSTERY NEO

Osc. Pedestal Fan



POLAR BLUSTERY NEO

2 YEARS WARRANTY

Features



BLACK-CHROME

BLACK-SILVER

-  Powerful & energy-efficient robust motor
-  Aerodynamically designed Aluminium blades for high air thrust and low noise
-  Autothermal overload protection
-  Smooth wide-angle oscillation
-  Telescopic arrangement for height adjustment
-  3-speed control rotary switch

- Unique and elegant large base design for better stability and enhanced aesthetic look
- Available in premium black powder-coating and chrome-finish guard with lacquer
- Anodised blades for long lasting & better finish
- Upward and downward tilt mechanism

TECHNICAL SPECIFICATIONS

Sweep
in mm
450

Power Input
in Watts
90

Speed
in RPM
1350

Air Delivery
in CMM
100



BLACK-SILVER

WINMILL

Osc. Pedestal Fan



POLAR WINMILL

2 YEARS WARRANTY

Features



100% Copper powerful & energy-efficient motor



Aerodynamically designed Aluminium blades for high-air thrust & delivery



Full metal construction



Autothermal overload protection



Telescopic arrangement for height adjustment



3-Speed control rotary switch

BLACK-SILVER

- Smooth wide angle oscillation
- Large & strong metal base for stability
- Upward & downward tilt mechanism
- Anodised blades for long lasting & better finish

TECHNICAL SPECIFICATIONS

Sweep in mm
400

Power Input in Watts
65

Speed in RPM
1350

Air Delivery in CMM
72

BLACK-SILVER



FANNY

Osc. Pedestal Fan



POLAR FANNY

2 YEARS WARRANTY



BLACK-SILVER

Features

 Powerful and energy-efficient 100% Copper motor

 Autothermal overload protection

 Jerk-free oscillation

 Strong and large metal base for better stability

 Aerodynamically balanced Aluminium blades for high air thrust

 Childproof guard

 3-speed push-button switch control

TECHNICAL SPECIFICATIONS

Sweep
in mm
400

Power Input
in Watts
65

Speed
in RPM
1350

Air Delivery
in CMM
72

- Upward and downward tilt mechanism
- Telescopic arrangement for height adjustment
- Anodised blades for long lasting & better finish

BLACK-SILVER



JETTY

Pedestal Fan



POLAR JETTY

1 YEAR WARRANTY



BLACK-SILVER

Features



Powerful and high-speed motor



High air delivery and throw



Round metal base for better stability



Aerodynamically designed Aluminium cast knife blades for high air thrust



Childproof guard

TECHNICAL SPECIFICATIONS

Sweep
in mm
450

Power Input
in Watts
140

Speed
in RPM
2500

Air Delivery
in CMM
80

- Telescopic arrangement for height adjustment

YELLOW-BLACK

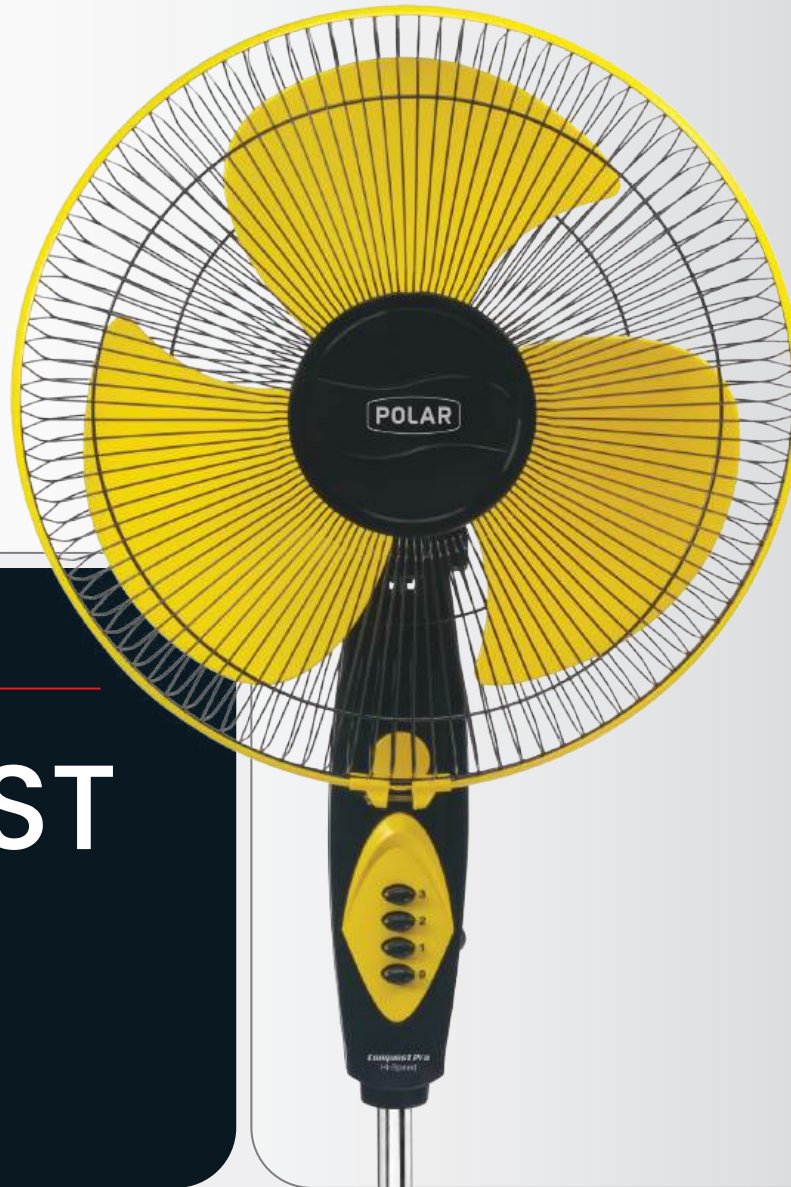

CONQUEST PRO

Osc. Pedestal Fan



POLAR CONQUEST PRO

2 YEARS WARRANTY

Features



CHERRY RED-BLACK
(HIGH SPEED)



YELLOW-BLACK
(HIGH SPEED)



CHERRY RED-BLACK
(NORMAL SPEED)



YELLOW-BLACK
(NORMAL SPEED)



Powerful and energy-efficient
100% Copper motor



Autothermal overload protection



Jerk-free oscillation



Strong and wide base for stability



Telescopic arrangement for height adjustment



Excellent air thrust and air delivery



Silent operation



3-speed push-button switch control

- Ratchet type tilting mechanism

TECHNICAL SPECIFICATIONS

Sweep in mm	Power Input in Watts	Speed in RPM	Air Delivery in CMM
Normal Speed			
400	65	1350	72
High Speed			
400	110	2200	95

WHITE-PURPLE

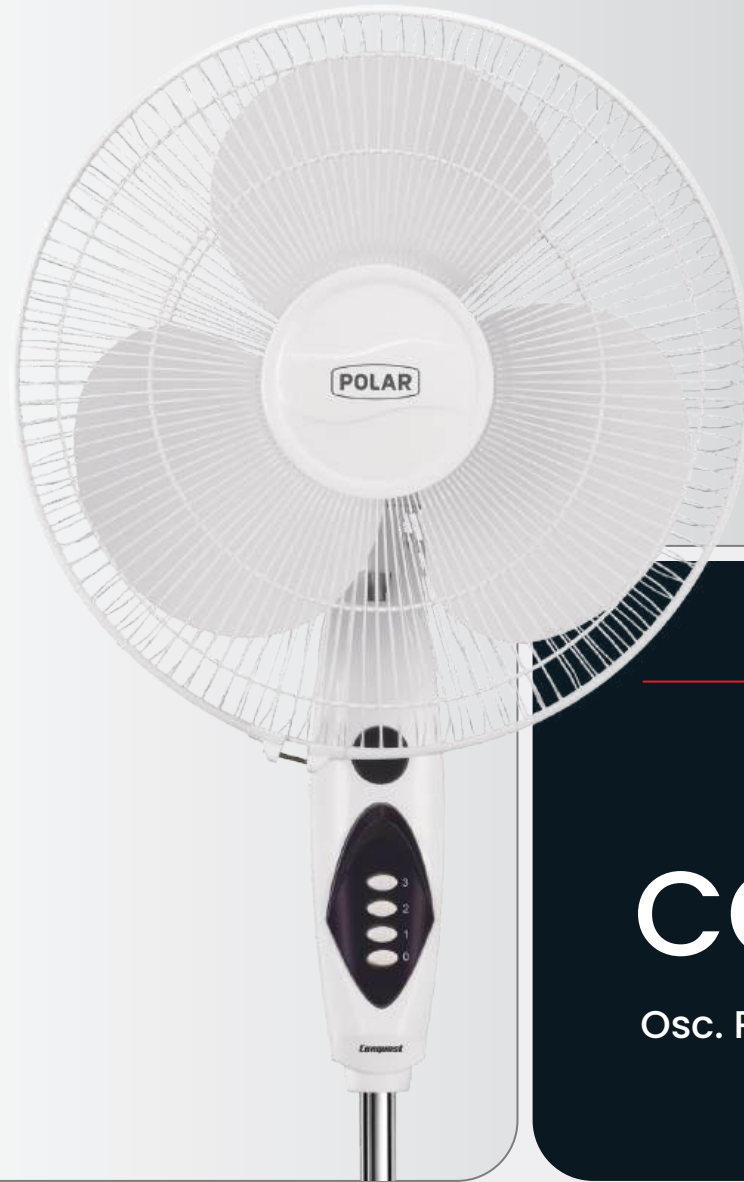

CONQUEST

Osc. Pedestal Fan



POLAR CONQUEST

2 YEARS WARRANTY



WHITE-PURPLE
(HIGH SPEED)

WHITE-PURPLE
(NORMAL SPEED)

Features



Powerful and energy-efficient
100% Copper motor



Autothermal overload protection



Jerk-free oscillation



Strong and large base for stability



Excellent air thrust and air delivery



Silent operation



3-speed push-button switch control

- Telescopic arrangement for height adjustment
- Ratchet type tilting mechanism

TECHNICAL SPECIFICATIONS

Sweep in mm	Power Input in Watts	Speed in RPM	Air Delivery in CMM
Normal Speed			
400	65	1350	72
High Speed			
400	110	2200	95

WHITE-MAUVE

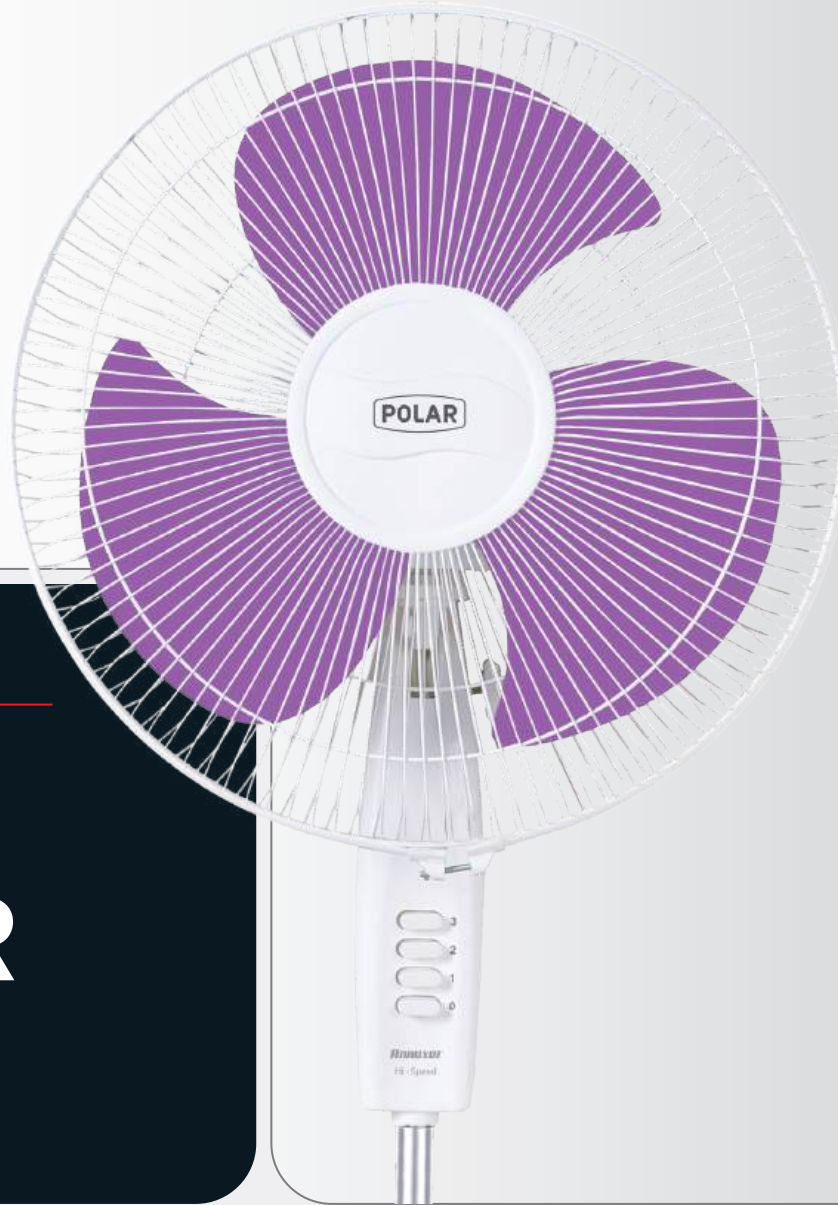

ANNEXER





R & SQ Osc. Pedestal Fan





POLAR ANNEXER

2 YEARS WARRANTY

Features

			
ANNEXER-SQ (HIGH SPEED) WHITE-MAUVE	ANNEXER-SQ (NORMAL SPEED) WHITE	ANNEXER-R (HIGH SPEED) WHITE-CHERRY RED	ANNEXER-R (NORMAL SPEED) WHITE-BLUE
AVAILABLE COLOURS	AVAILABLE COLOURS	AVAILABLE COLOURS	AVAILABLE COLOURS
<input type="radio"/> WHITE-MAUVE <input type="radio"/> WHITE-PURPLE <input type="radio"/> WHITE	<input type="radio"/> WHITE-BLUE <input type="radio"/> WHITE-CHERRY RED <input type="radio"/> WHITE	<input type="radio"/> WHITE-PURPLE <input type="radio"/> WHITE-CHERRY RED <input type="radio"/> WHITE	<input type="radio"/> WHITE-BLUE <input type="radio"/> WHITE-CHERRY RED <input type="radio"/> WHITE

-  Powerful and energy-efficient 100% Copper motor
-  Autothermal overload protection
-  Jerk-free oscillation
-  Telescopic arrangement for height adjustment
-  Excellent air thrust and air delivery
-  Silent operation
-  3-speed push-button switch control

TECHNICAL SPECIFICATIONS

Model Name	Sweep in mm	Power Input in Watts	Speed in RPM	Air Delivery in CMM
Normal Speed				
Annexer-R & SQ	400	65	1350	72
High Speed				
Annexer-R & SQ	400	110	2200	95

- Upward and downward tilt mechanism

WHITE-MAROON

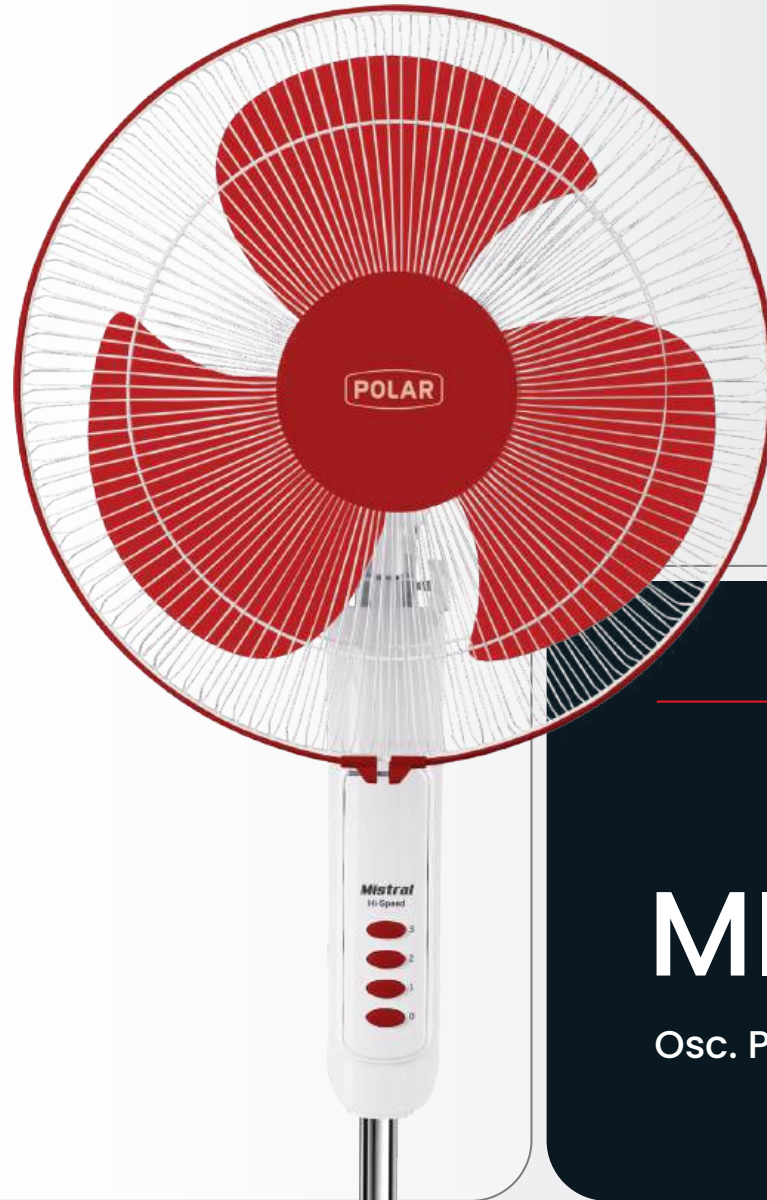

MISTRAL

Osc. Pedestal Fan









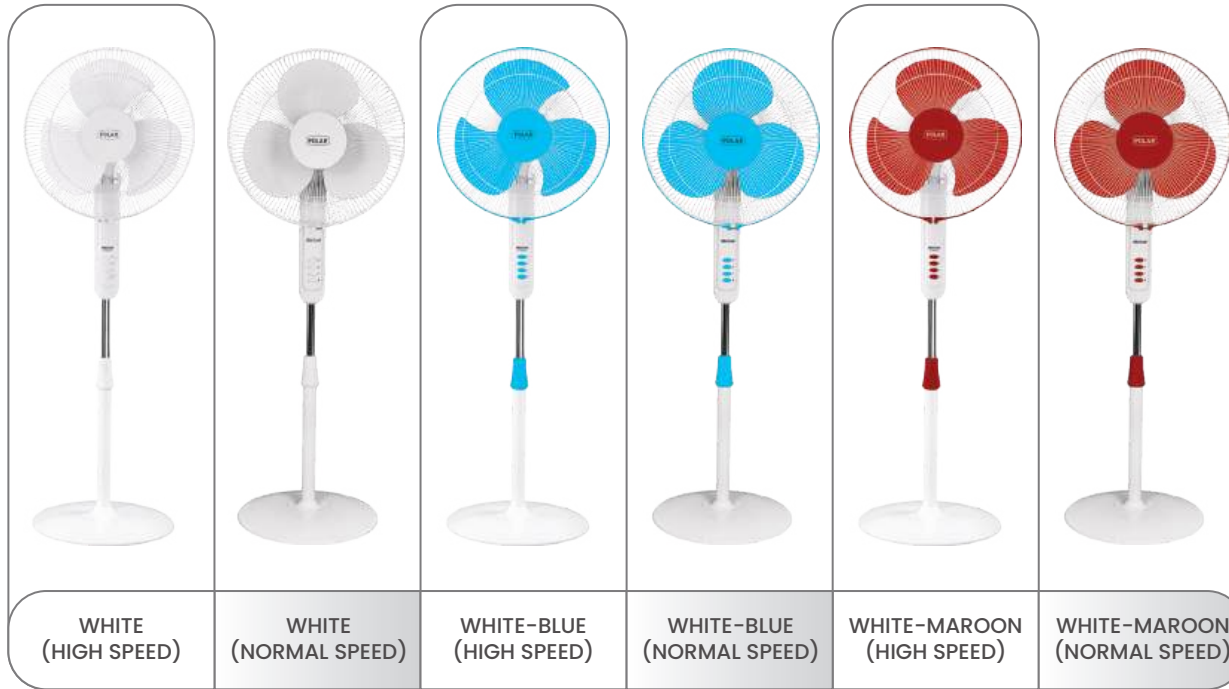

POLAR MISTRAL

2 YEARS WARRANTY

Features



-  Powerful and energy-efficient 100% Copper motor
-  Autothermal overload protection
-  Jerk-free oscillation
-  Strong & large base for better stability
-  Telescopic arrangement for height adjustment
-  Silent operation
-  Upward and downward tilt mechanism
-  3-speed push-button switch control

- Excellent air thrust & air delivery
- Childproof guard

TECHNICAL SPECIFICATIONS

Sweep in mm	Power Input in Watts	Speed in RPM	Air Delivery in CMM
Normal Speed			
400	65	1350	72
High Speed			
400	110	2200	95

BLACK-SILVER

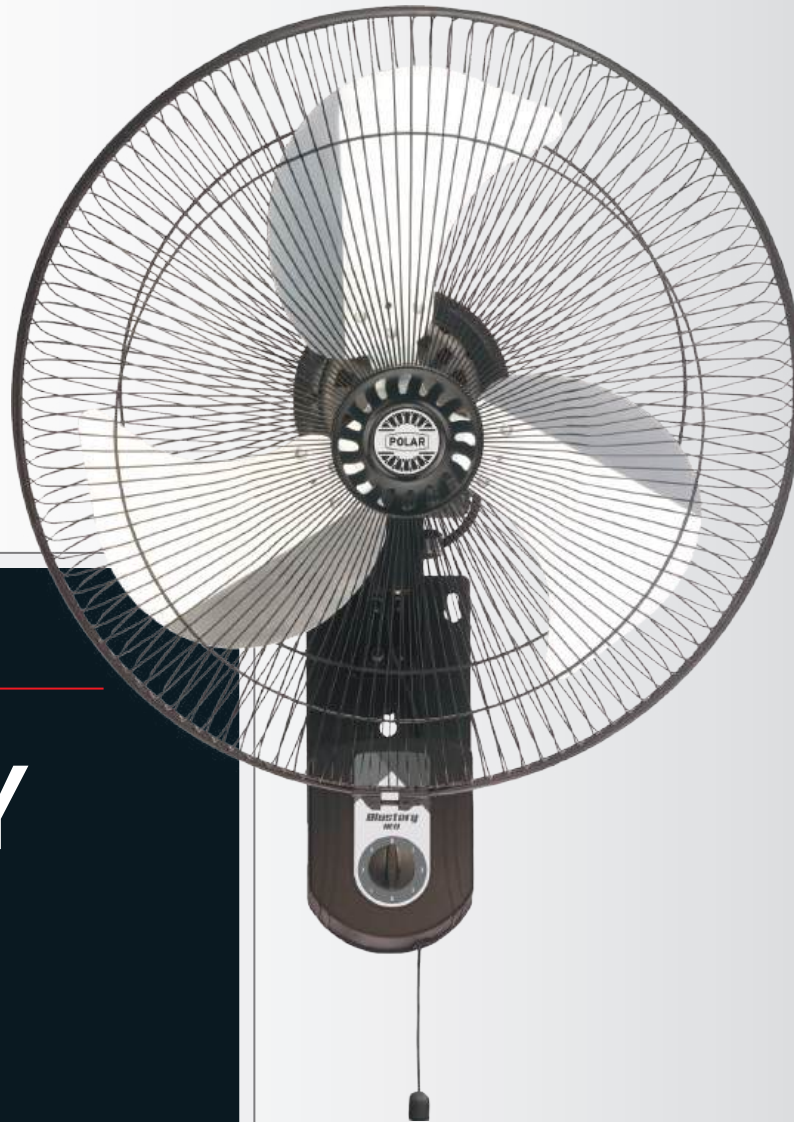

BLUSTERY NEO

Osc. Wall Fan



POLAR BLUSTERY NEO

2 YEARS WARRANTY

Features



BLACK-SILVER



Powerful & energy-efficient robust motor



Full metal construction



Autothermal overload protection



Wide-angle oscillation



Upward and downward tilt mechanism



Pull-cord mechanism for 3-speed control



Aerodynamically designed Aluminium blades for high air thrust and delivery

- Anodised blades for long lasting & better finish
- Available in premium black powder coated and chromo finish guard with lacquer

TECHNICAL SPECIFICATIONS

Sweep in mm
450

Power Input in Watts
90

Speed in RPM
1350

Air Delivery in CMM
100

BLACK-SILVER



FANNY

Osc. Wall Fan



POLAR FANNY

2 YEARS WARRANTY



BLACK-SILVER

Features



Powerful and energy-efficient 100% Copper motor



Autothermal overload protection



Jerk-free oscillation



Silent operation



Upward and downward tilt mechanism



Aerodynamically balanced Aluminium blades for high air thrust



Pull cord mechanism for oscillation and 3-speed control along with ON/OFF

TECHNICAL SPECIFICATIONS

Sweep in mm
400

Power Input in Watts
65

Speed in RPM
1350

Air Delivery in CMM
72

- Extra ribs on the front and back guard for enhanced safety
- Anodised blades for long lasting & better finish

75

WHITE-MAROON



MISTRAL

Osc. Wall Fan



POLAR MISTRAL

2 YEARS WARRANTY

Features



WHITE-BLUE
(HIGH SPEED)



WHITE-MAROON
(HIGH SPEED)



WHITE
(HIGH SPEED)

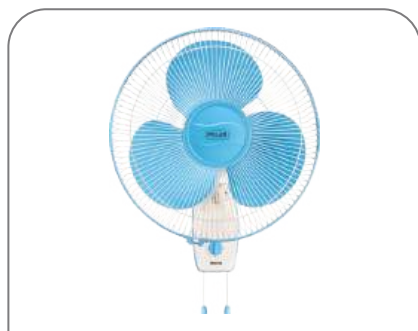

WHITE-BLUE
(NORMAL SPEED)



WHITE-MAROON
(NORMAL SPEED)



WHITE
(NORMAL SPEED)



Powerful and energy-efficient
100% Copper motor



Autothermal overload protection



Jerk-free smooth oscillation



Silent operation



Upward and downward tilt mechanism



Aerodynamically balanced blades for high air delivery



Pull-cord for oscillation & speed control

TECHNICAL SPECIFICATIONS

Sweep in mm	Power Input in Watts	Speed in RPM	Air Delivery in CMM
Normal Speed			
400	65	1350	72
High Speed			
400	110	2200	95

- Sleek & stylish aesthetic look
- 3-speed rotary switch for speed control

YELLOW - BLACK

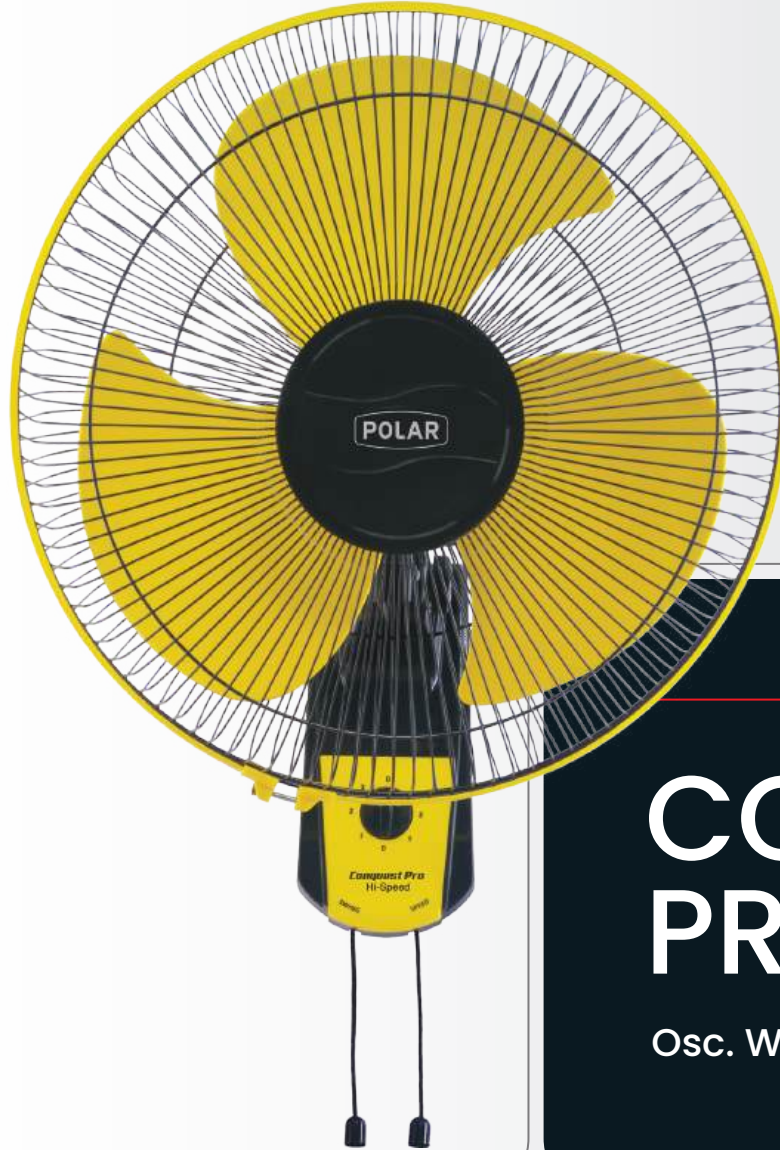

CONQUEST PRO

Osc. Wall Fan



POLAR CONQUEST PRO

2 YEARS WARRANTY

Features



YELLOW-BLACK
(HIGH SPEED)

CHERRY RED-BLACK
(HIGH SPEED)



YELLOW-BLACK
(NORMAL SPEED)

CHERRY RED-BLACK
(NORMAL SPEED)



Powerful and energy-efficient 100% Copper motor



Autothermal overload protection



Jerk-free smooth oscillation



Silent operation



Excellent air thrust and air delivery



Pull-cord for oscillation and 3-speed control

TECHNICAL SPECIFICATIONS

Sweep in mm	Power Input in Watts	Speed in RPM	Air Delivery in CMM
Normal Speed			
400	65	1350	72
High Speed			
400	110	2200	95

- Ratchet type tilting mechanism

WHITE-PURPLE

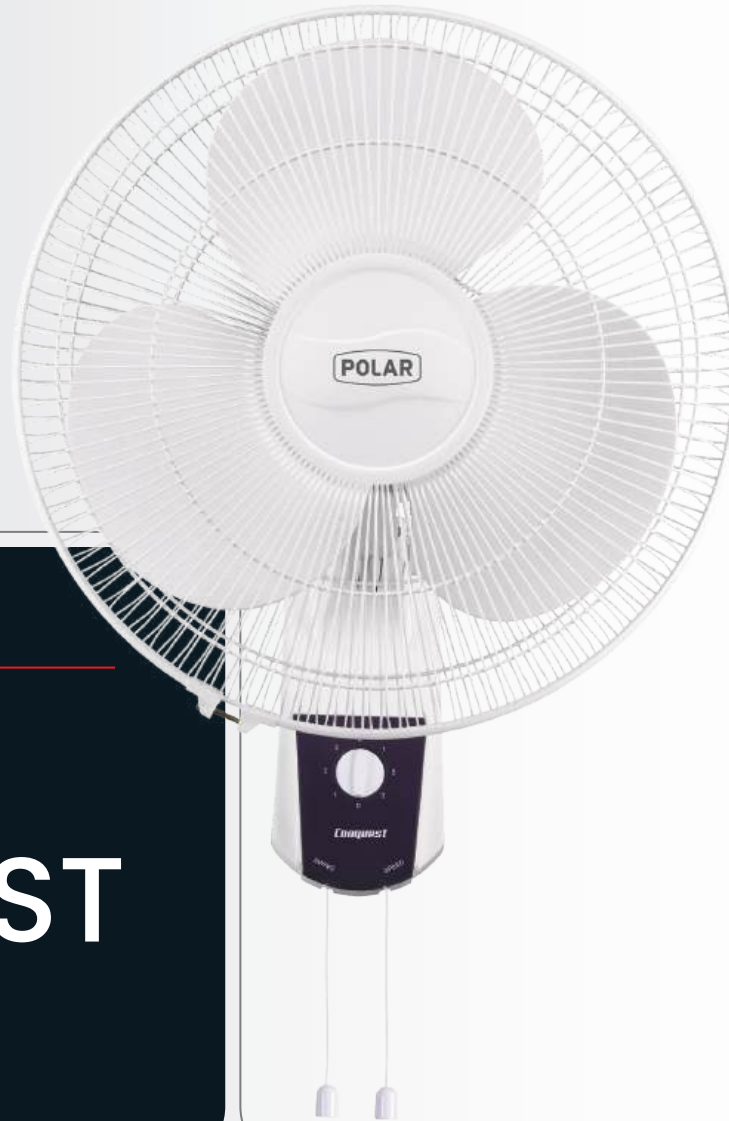

CONQUEST

Osc. Wall Fan



POLAR CONQUEST

2 YEARS WARRANTY



WHITE-PURPLE
(HIGH SPEED)

WHITE-PURPLE
(NORMAL SPEED)

Features



Powerful and energy-efficient
100% Copper motor



Autothermal overload protection



Jerk-free smooth oscillation



Silent operation



Excellent air thrust and air delivery



Pull-cord for oscillation and 3-speed control

- Ratchet type tilting mechanism

TECHNICAL SPECIFICATIONS

Sweep in mm	Power Input in Watts	Speed in RPM	Air Delivery in CMM
Normal Speed			
400	65	1350	72
High Speed			
400	110	2200	95

BLACK

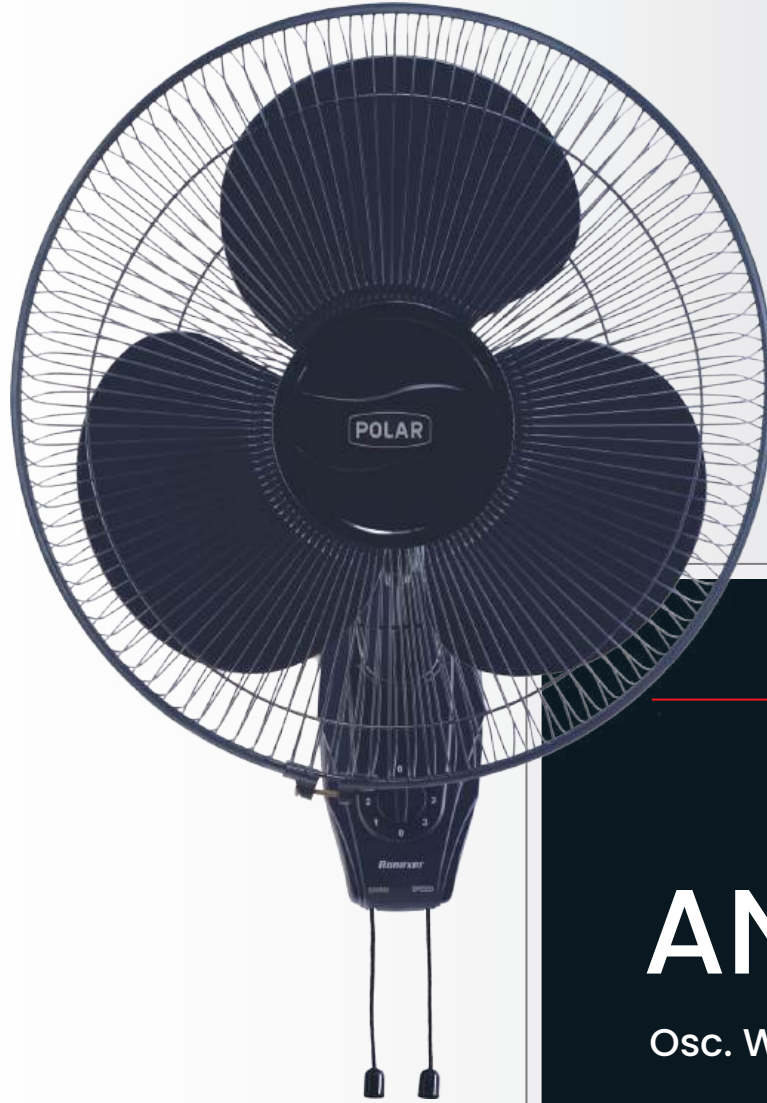

ANNEXER

Osc. Wall Fan



POLAR ANNEXER

2 YEARS WARRANTY

Features

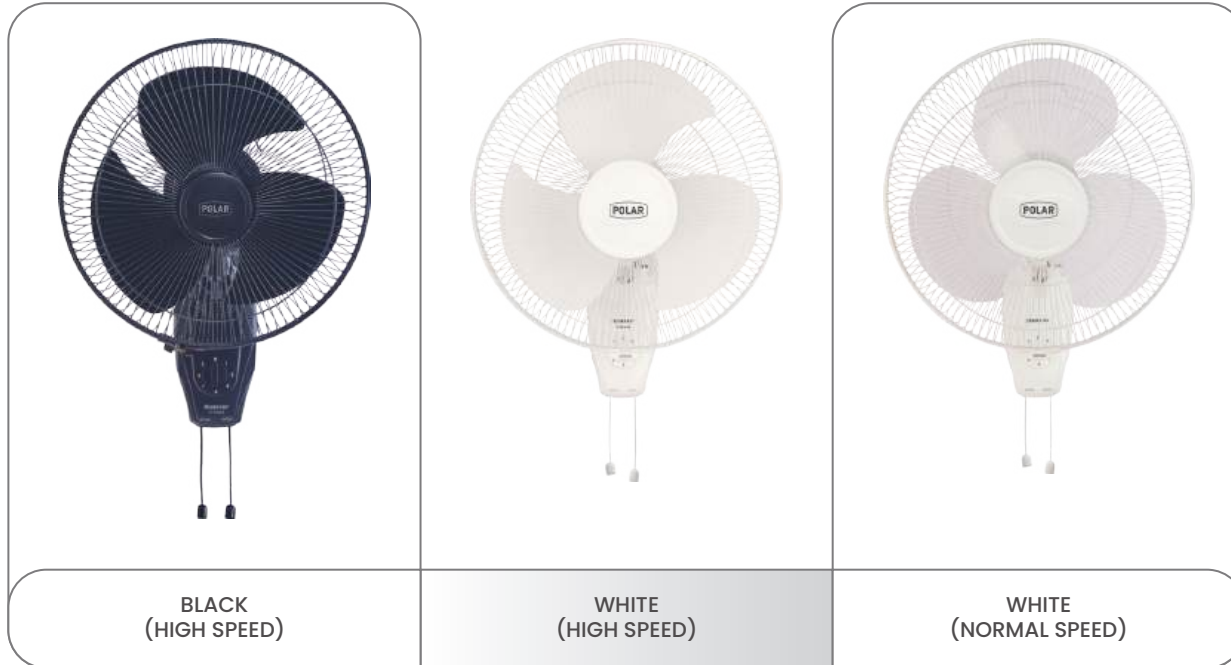

-  Powerful and energy-efficient 100% Copper motor
-  Autothermal overload protection
-  Jerk-free oscillation
-  Upward and downward tilt mechanism
-  Aerodynamically designed high-grade polymer blades for maximum air delivery
-  Pull-cord for oscillation and 3-speed control

TECHNICAL SPECIFICATIONS

Sweep in MM	Power Input in Watts	Speed in RPM	Air Delivery in CMM
Normal Speed			
400	65	1350	72
High Speed			
300	95	2200	72
400	110	2200	95

- Excellent air thrust and air delivery

BLACK-SILVER

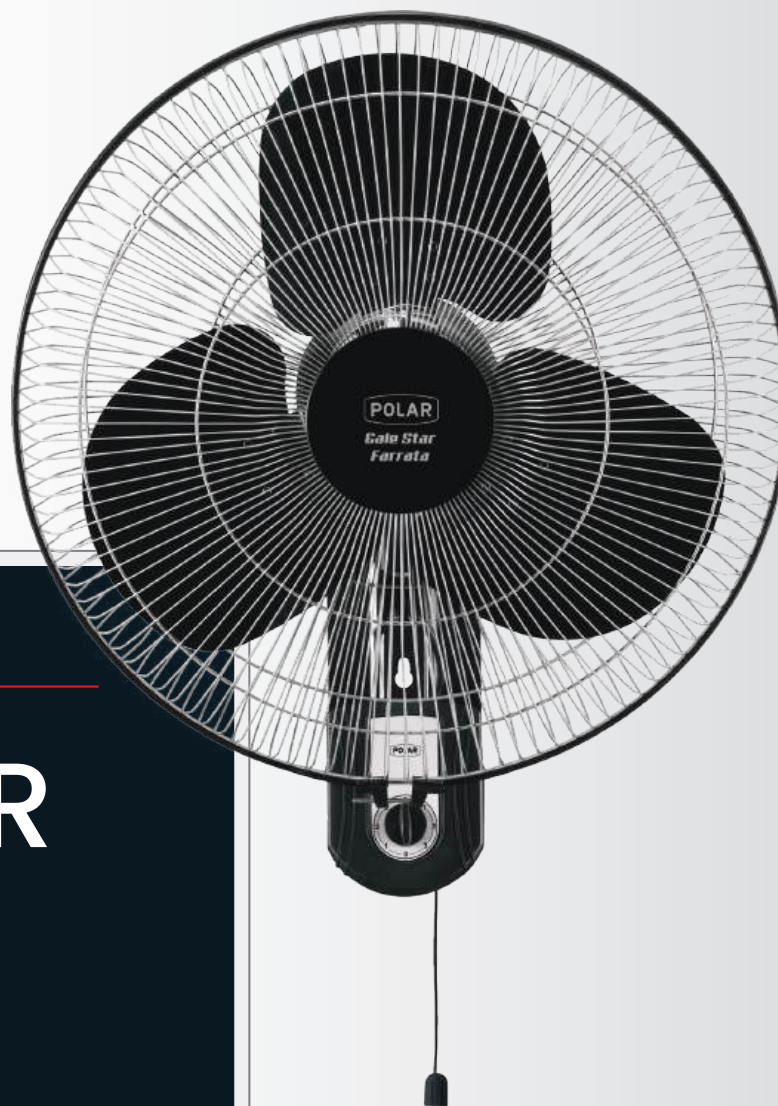

GALESTAR FARRATA

Osc. Wall Fan





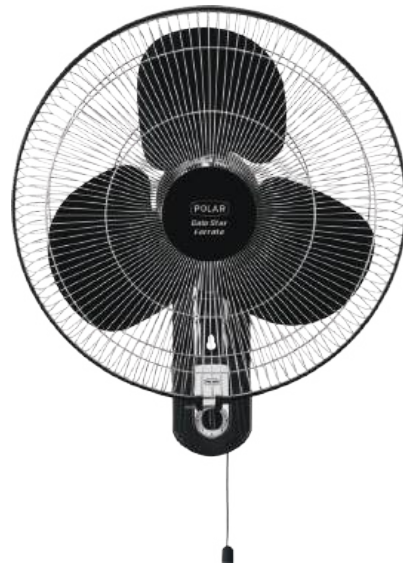

POLAR GALESTAR FARRATA

1 YEAR WARRANTY



BLACK-SILVER

Features

-  Heavy-duty double ball bearing motor for better energy efficiency & durability
-  Pull-cord for 3-speed control and on/off
-  Vibration-free operation
-  Smooth wide-angle oscillation
-  Unique & strong wall stand design

- Aerodynamically designed and well-balanced broad 3-leaf metal blades for excellent air thrust
- Sturdy close wire mesh guard for extra safety
- Metal construction
- Upward and downward tilt mechanism
- Powder-coated finish for corrosion resistance and longer life

TECHNICAL SPECIFICATIONS

Sweep
in mm
500

Power Input
in Watts
140

Speed
in RPM
1400

Air Delivery
in CMM
120

WHITE-PURPLE

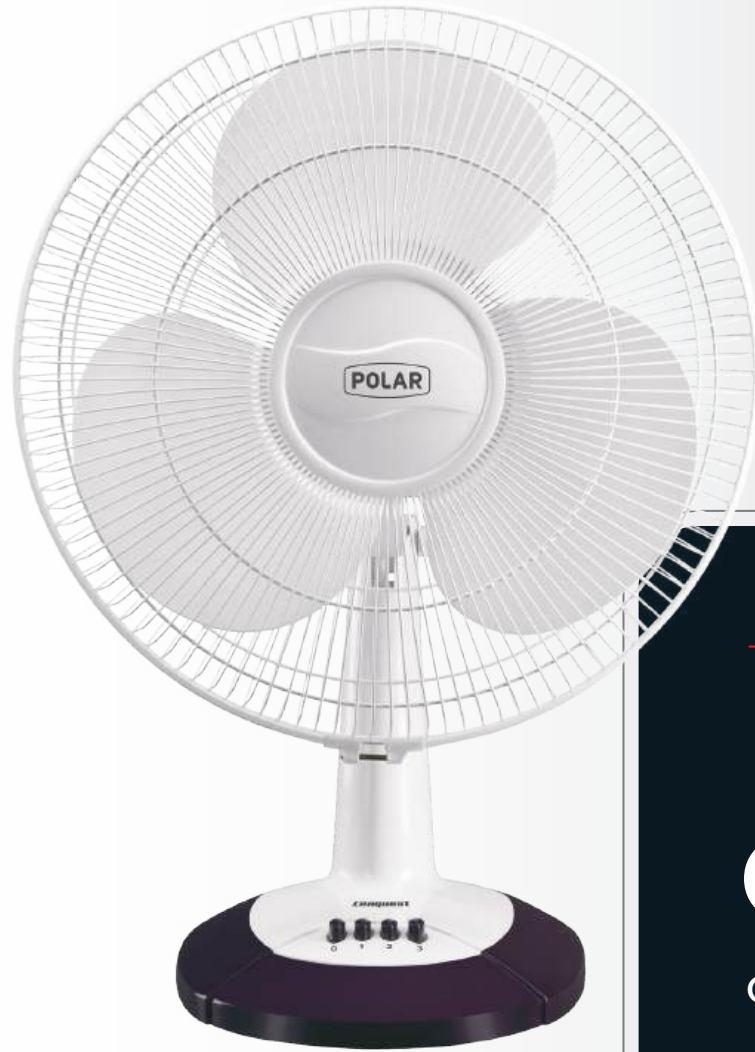

CONQUEST

Osc. Table Fan



POLAR CONQUEST

2 YEARS WARRANTY

Features



WHITE-PURPLE
(HIGH SPEED)

WHITE-PURPLE
(NORMAL SPEED)

 Powerful and energy-efficient 100% Copper motor

 Autothermal overload protection

 Jerk-free oscillation

 Strong and large base for better stability

 Silent operation

 Excellent air thrust and air delivery

- 3-speed push-bottom switch control
- Ratchet type tilting mechanism

TECHNICAL SPECIFICATIONS

Sweep in MM	Power Input in Watts	Speed in RPM	Air Delivery in CMM
Normal Speed			
400	65	1350	72
High Speed			
400	110	2200	95

WHITE-MAUVE

ANNEXER

Osc. Table Fan

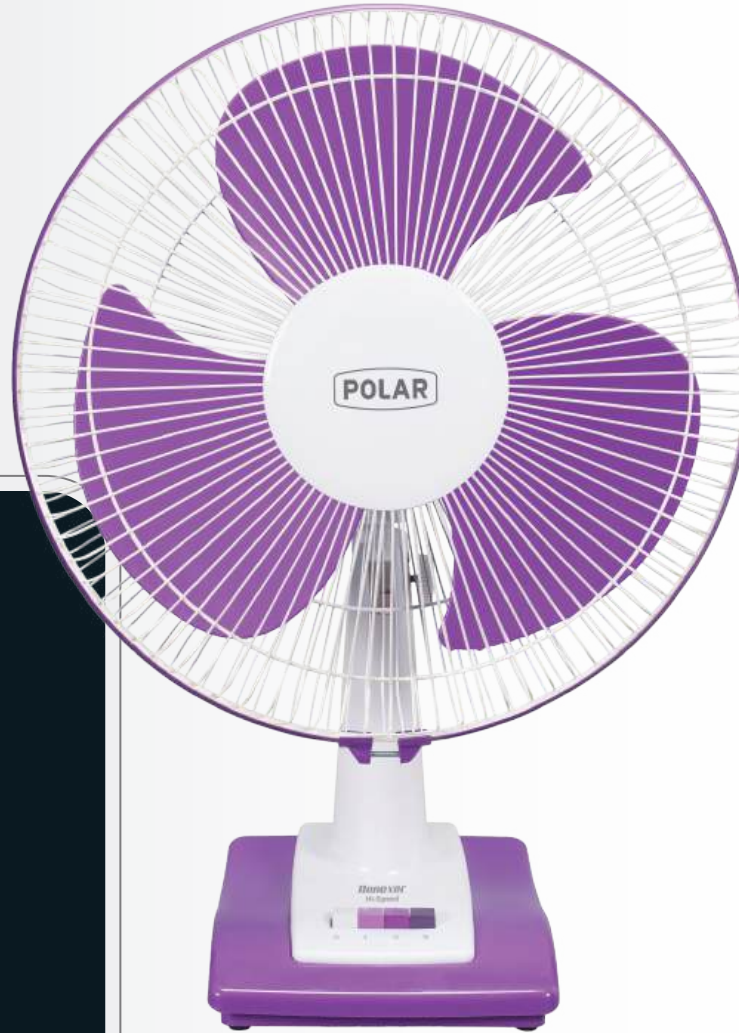

POLAR ANNEXER

2 YEARS WARRANTY

Features



WHITE-BLUE
(HIGH SPEED)

WHITE-MAUVE
(HIGH SPEED)



WHITE-BLUE
(NORMAL SPEED)

WHITE-MAUVE
(NORMAL SPEED)

-  Powerful and energy-efficient 100% Copper motor
-  Autothermal overload protection
-  Smooth wide-angle oscillation
-  Strong and large base for better stability
-  Silent operation
-  Upward and downward tilt mechanism
-  3-speed push-button switch control

- Extra protection against corrosion with powder-coated guard and polymer ring
- Aerodynamically designed high-grade polymer blades for maximum air delivery

TECHNICAL SPECIFICATIONS

Sweep in mm	Power Input in Watts	Speed in RPM	Air Delivery in CMM
Normal Speed			
400	65	1350	72
High Speed			
400	110	2200	95

WHITE-MAROON

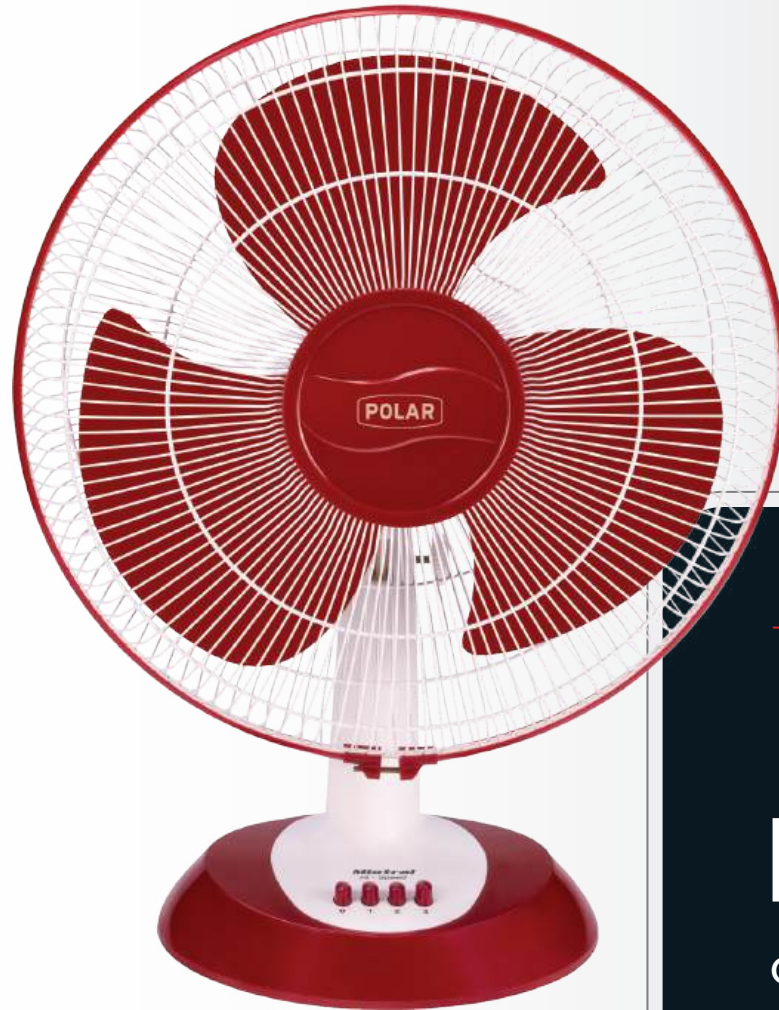

MISTRAL

Osc. Table Fan



POLAR MISTRAL

2 YEARS WARRANTY

Features



WHITE-BLUE
(HIGH SPEED)



WHITE-MAROON
(HIGH SPEED)



WHITE
(HIGH SPEED)



WHITE-BLUE
(NORMAL SPEED)



WHITE-MAROON
(NORMAL SPEED)



WHITE
(NORMAL SPEED)

 Powerful and energy-efficient 100% Copper motor

 Autothermal overload protection

 Smooth wide-angle oscillation

 Strong and large base for better stability

 Upward and downward tilt mechanism

 3-speed push-button switch control

- Aerodynamically designed high-grade polymer blades for maximum air delivery

TECHNICAL SPECIFICATIONS

Sweep in mm	Power Input in Watts	Speed in RPM	Air Delivery in CMM
Normal Speed			
400	65	1350	72
High Speed			
400	110	2200	95

Multi-purpose Fans

A **DYNAMIC**
RANGE FOR
SMALL
SPACES



WHITE-GREY



ANNEXER

All-purpose Fan



POLAR ANNEXER

1 YEAR WARRANTY

Features



Energy-efficient & powerful motor for durability



Scientifically profiled high-grade polymer blades for high air thrust



3-speed control rotary switch



Extra protection against corrosion with powder-coated guard and polymer ring

WHITE-GREY
(HIGH SPEED)

TECHNICAL SPECIFICATIONS

Sweep
in mm
300

Power Input
in Watts
80

Speed
in RPM
2300

Air Delivery
in CMM
80

- 2-in-1 advantages of wall mounting & table/desktop usage

BLACK-CHROME

STORMY NEO

Multi-utility Fan



POLAR STORMY NEO

2 YEARS WARRANTY

Features

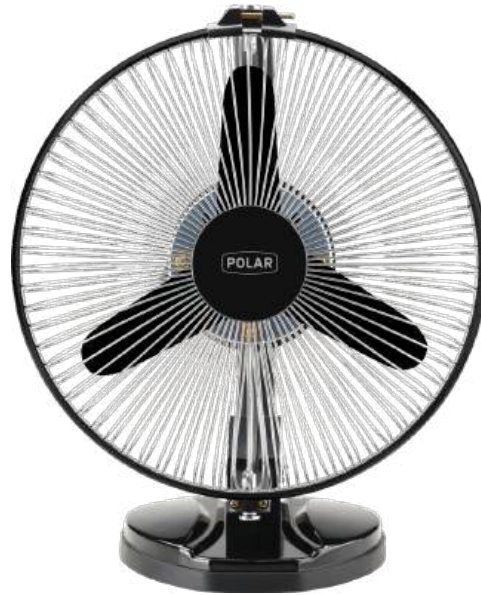

Heavy-duty robust motor for durability



2800 RPM for high air thrust



Novel rocker arrangement to swivel by 360° horizontally & 180° vertically

BLACK-CHROME
(HIGH SPEED)

TECHNICAL SPECIFICATIONS

Sweep
in mm
230

Power Input
in Watts
45

Speed
in RPM
2800

Air Delivery
in CMM
26

Air Velocity
in M/Min
268

- 2-in-1 advantages of wall mounting & table/desktop usage

WHITE

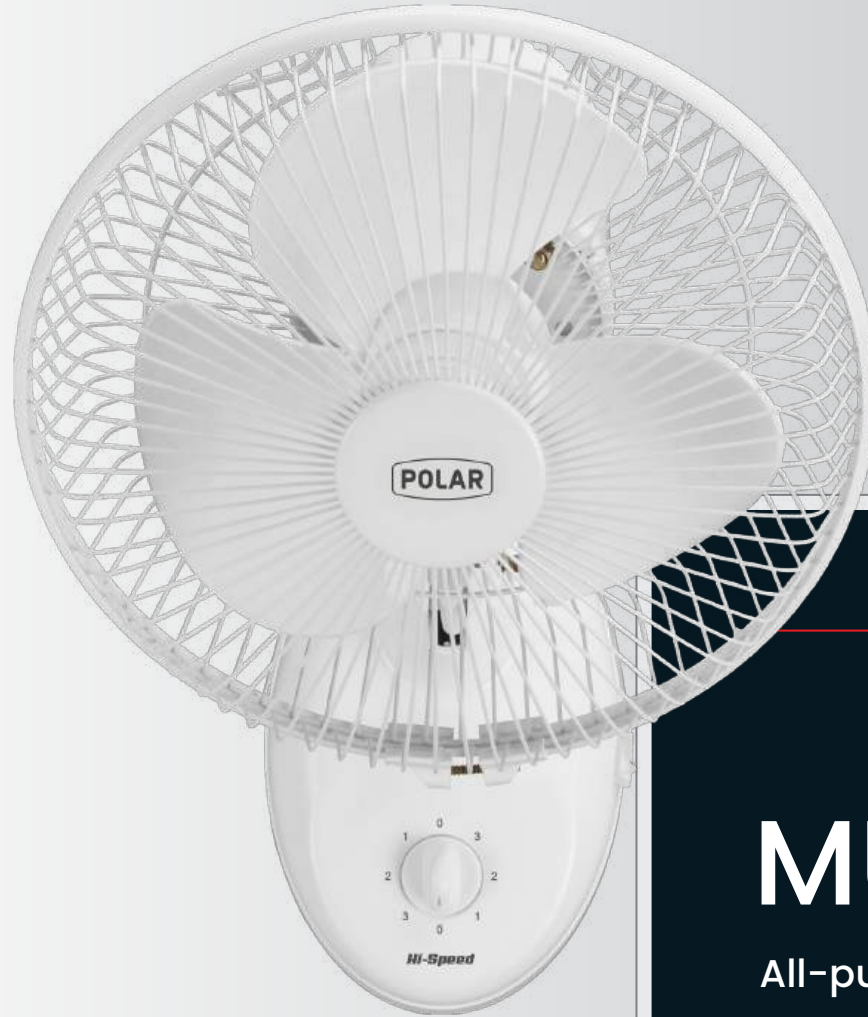

MUF

All-purpose Fan



POLAR MUF

2 YEARS WARRANTY

Features



High speed
2600 RPM



Heavy-duty
powerful
motor



Autothermal
overload protection



3-speed
operation



Oscillation with
synchronous
motor

WHITE

**TECHNICAL
SPECIFICATIONS**

Sweep
in mm
230

Power Input
in Watts
50

Speed
in RPM
2600

Air Delivery
in CMM
28

- 2-in-1 advantages of wall mounting & table/desktop usage

WHITE

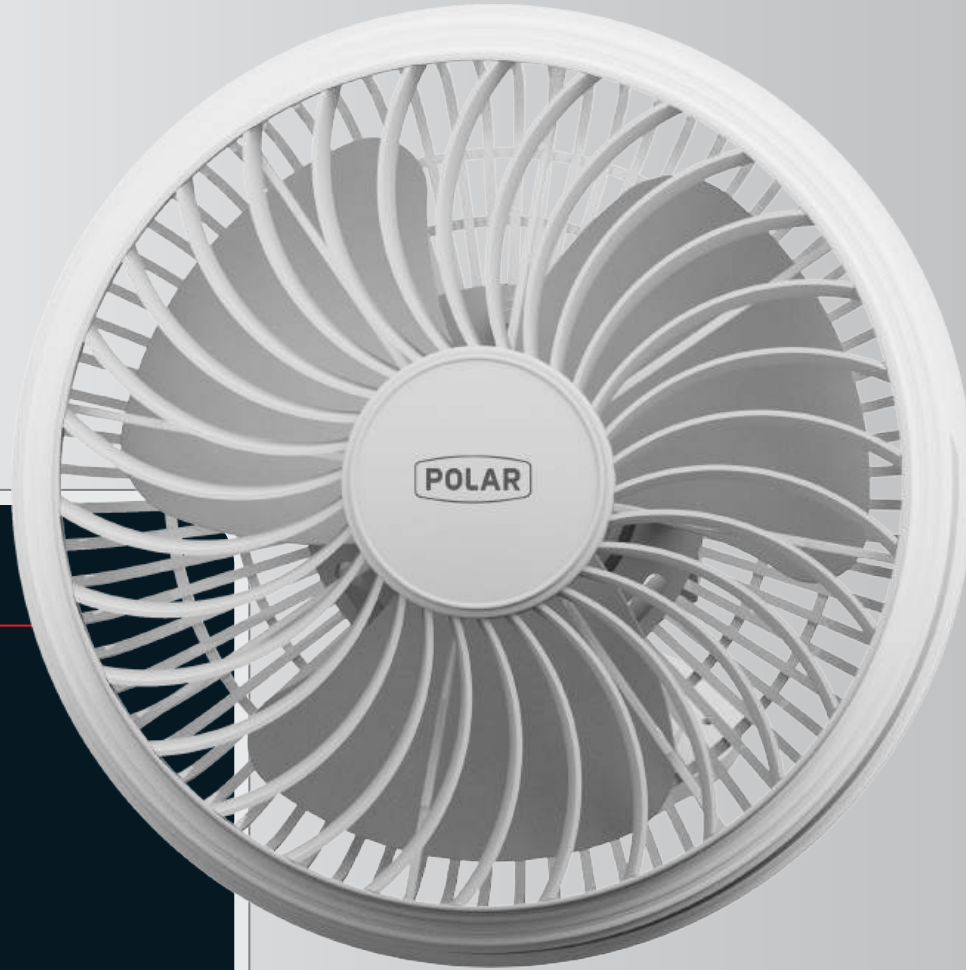

STORMY

Cabin Fan



POLAR STORMY

2 YEARS WARRANTY

Features



WHITE



100% Copper motor for durability



All-round air delivery with rotating grille



Powerful motor for high air delivery



High-grade polymer revolving grille



Overheat protection



Aerodynamic blades for faster speed and high air delivery

TECHNICAL SPECIFICATIONS

Sweep in mm
300

Power Input in Watts
70

Speed in RPM
2100

Air Delivery in CMM
58

- 2-in-1 advantages of wall mounting & ceiling usage

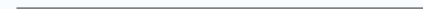

FRESH
INDOORS
ALWAYS

Exhaust Fans

CLEAN AIR DUO



CLEAN AIR

Metal Exhaust Fan





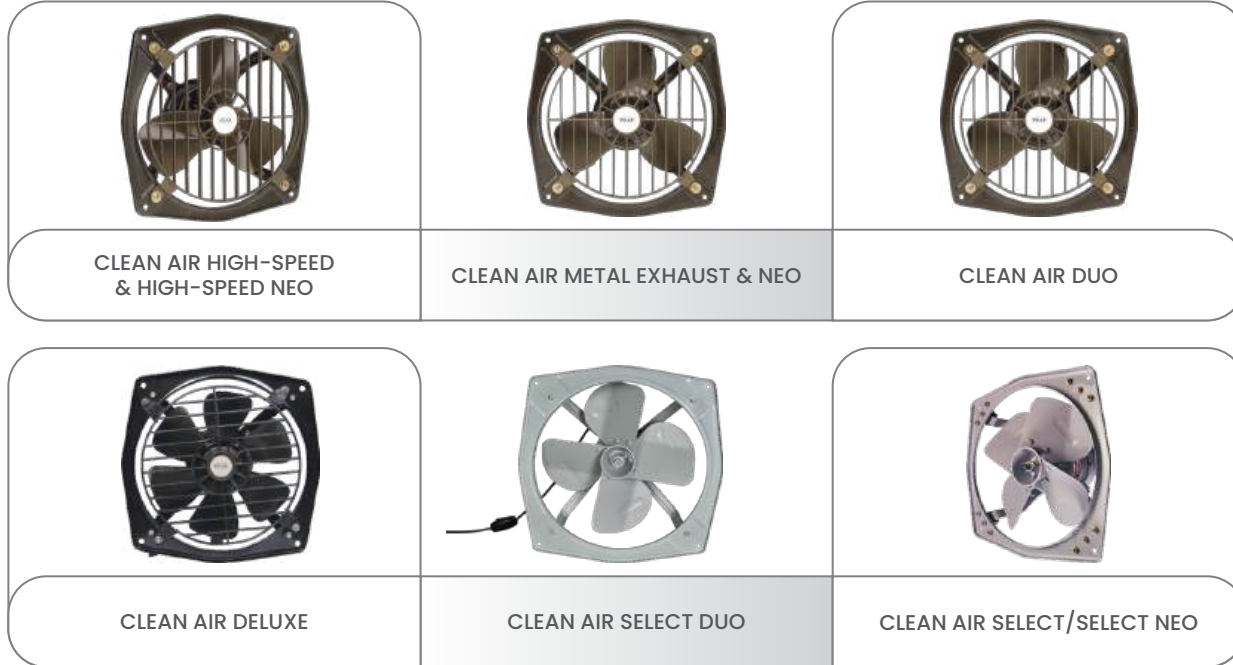

POLAR CLEAN AIR

2 YEARS WARRANTY



Features

-  Robust motor for powerful performance and longer life
-  Metal/resin blades with safety guard (optional) for longer life
-  Clean Air Duo & Clean Air Select Duo rotate in both clockwise & anti-clockwise directions
-  High-speed model with a powerful motor and high air suction
-  Powder-coated finish

TECHNICAL SPECIFICATIONS

Model Name	Sweep in mm	Power Input in Watts	Speed in RPM	Air Delivery in CMH
Clean Air Select	150/230/300	40/42/65	2600/1350/1300	550/750/1750
Clean Air Select Neo	230/300	45/80	1350/1350	750/1750
Clean Air High-speed	230	60	2650	950
Clean Air Metal Exhaust & Neo	230/300	40/50	1350/1300	520/1250
Clean Air Duo	230	60	2650	950/900
Clean Air High-speed Neo	230/300	60/70	2600/2500	950/1750
Clean Air Deluxe	230/300	40/65	1300/1270	650/1250
Clean Air Select Duo	230	40	1350	750/550
Clean Air Select Duo	300	65	1300	1750/1050

- Clean Air Select has double ball bearings and heavy-duty 4-leaf blades, and it is mounted on an Aluminium carrier and powder-coated metallic coloured carrier
- Clean Air Deluxe and Clean Air Metal Exhaust are available with a non-capacitor motor
- Ideal for kitchens, bathrooms, restaurants and also for low-end industrial use (for selected models)

CLEAN AIR PASSION-VH



CLEAN AIR





Plastic Ventilating Fan



POLAR CLEAN AIR

2 YEARS WARRANTY

Features

			
CLEAN AIR PASSION*	CLEAN AIR PASSION NEO*	CLEAN AIR PASSION BLDC*	AXIAL FLOW (AF)*
			<p>*AVAILABLE COLOURS:</p> <ul style="list-style-type: none"> <input type="radio"/> WHITE <input type="radio"/> IVORY <input type="radio"/> BLACK <p>**AVAILABLE COLOURS:</p> <ul style="list-style-type: none"> <input type="radio"/> WHITE <input type="radio"/> IVORY <input type="radio"/> WOOD FINISH
AXIAL FLOW PLUS & BLDC	AXIAL FLOW NEO	CLEAN AIR-VH**	

-  Robust motor for powerful performance and longer life
-  High-grade thermoplastic polymer body and blades
-  Powerful air suction for fresh & odourless air
-  Lightweight rust-proof body
-  Overheat protection

TECHNICAL SPECIFICATIONS

Model Name	Sweep in mm	Power Input in Watts	Speed in RPM	Air Delivery in CMH
Clean Air Passion-Axial Flow	100/150/200	18/24/25	2500/1800/2000	90/250/350
Axial Flow Plus & Neo	100/150/200	18/24/25	2500/1800/2000	90/250/350
Axial Flow Plus BLDC	150	9	2000	260
Clean Air Passion-VH	100/150	18/24	2500/1800	85/220
Clean Air Passion Neo	150/200/250	32/35/37	1350/1300/1250	300/500/750
Clean Air Passion BLDC	150/200/250	6/12/14	1350/1350/1350	250/500/750
Normal Speed				
Clean Air Passion	150/200/250	32/35/37	1350/1300/1250	300/500/750
High Speed				
Clean Air Passion	150/200	50/65	2500/2100	500/750

- Self-open and close shutter to prevent dust and foreign materials (on select models only)
- Easy screw-less installation, Axial Flow models can be mounted on glass
- Convenient removal of front shutter for easy cleaning (VH)
- Powerful & energy-efficient BLDC motor for low electricity consumption (BLDC model)

Commercial Fans

COMFORT
IN EVERY
CORNER





BLACK-SILVER

GALESTAR

Air Circulator



POLAR GALESTAR

1 YEAR WARRANTY







BLACK-SILVER



BLACK-SILVER

Features

-  Heavy-duty and powerful 100% Copper motor
-  Heavy and robust base for better stability
-  Powder-coated paint with a metallic finish protects the fan from corrosion
-  Aerodynamically designed Aluminium blades for high air delivery
-  Double ball bearings for longer life

- Heavy-duty and powerful motor for optimum performance even at low voltage
- Precision-built oscillating mechanism with an indexing option and 90° oscillation
- Performance generally conforms to IS-2997-1964 with up-to-date amendments

TECHNICAL SPECIFICATIONS

Sweep in mm	Power Input in Watts	Speed in RPM	Air Delivery in CMM	Min. Peak Air Velocity in M/Min
450	100	1400	150	250
600	180	1400	280	250
750	250	1400	370	245

WINDPOWER NEO



WINDPOWER & WINDPOWER NEO



Heavy-duty Metal Ventilating Fan



POLAR WINDPOWER & WINDPOWER NEO

2 YEARS WARRANTY

Features

-  Powerful and efficient robust motor with double-ball-bearings for longer life
-  ISI approved
-  Anti-corrosive powder-coated glossy finish

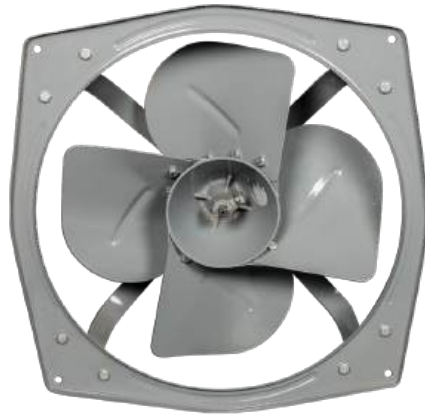

Windpower

Windpower Neo

- Designed to effectively combat pollution and remove smoke, dust and other pollutants, keeping the workplace clean and fresh
- Available in IP-55 degree enclosure for protection against dust & water ingress
- Dynamically balanced heavy-duty impeller
- Available to suit single-phase and 3-phase supply

TECHNICAL SPECIFICATIONS

Sweep in mm	Power Input in Watts	Speed in RPM	Air Delivery in CMH (under free airflow condition)
300	82	1400	1900
300	50	900*	1270
380	150	1400	3600
380	90	900*	2220
450	370	1400	6800
450	132	900*	4340
600	500	900*	10450

*100% Copper motor

BLACK-SILVER



COOLER KIT



POLAR COOLER KIT

1 YEAR WARRANTY

Features



COOLER FAN



MINI SUBMERSIBLE PUMP



Powerful and energy-efficient capacitor-type motor



Bronze bush with adequate lubrication for enhanced life

TECHNICAL SPECIFICATIONS

Cooler Motor

Sweep in mm	Power Input in Watts	Speed in RPM	H. P.	Max. AMP.
300	105	2700	1/10	0.5
400	150	1400	1/7	0.7
450	350	1400	1/4	1.7

Mini Submersible Pump

Type	Power Consumption in Watts	Maximum Head	Maximum Flow	Max. Cooler Height Recommended
Regular	18	1.8 mtrs.	800 LPH	1.2 mtrs.
Jumbo	38	2.8 mtrs.	1200 LPH	1.8 mtrs.

Cooler Fan

Sweep in mm	Power Input in Watts	Speed in RPM	Air Delivery in CMH
500	150	1400	6000

- Broadleaf in Aluminium sheet, scientifically designed and mounted on MS carrier to make sturdy construction and produce high air delivery
- Essential gadget for room/desert coolers used in domestic/commercial establishments for maximum cooling
- Mini submersible pump in a normal and jumbo model takes care of high water flow with a higher delivery head

INSTALLATION DIAGRAM

CLEAN AIR PASSION

Dimensional Guidelines for Installation

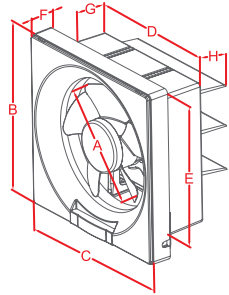

All sizes are in mm

A (Sweep)	B	C	D	E	F	G	H
150	243	243	175	175	32	84	70
200	293	293	242	242	42	89	58
250	345	345	292	292	42	89	71

Installation Instruction

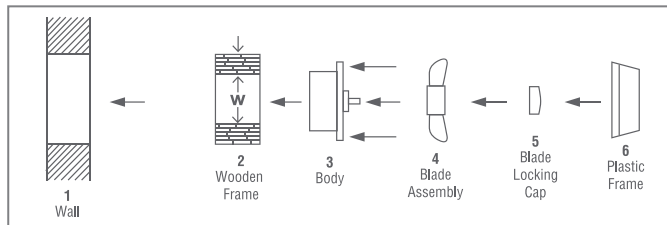

Connection Diagram

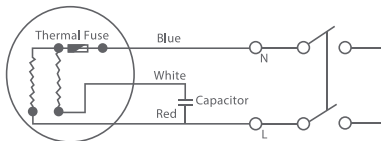

Wooden Frame Cutout Sizes

- 177 × 177 (for 150 mm)
- 245 × 245 (for 200 mm)
- 295 × 295 (for 250 mm)

AXIAL FLOW

Cutout Size Guidelines

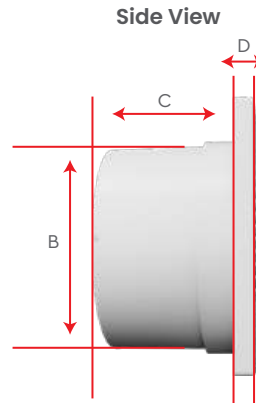

Front View

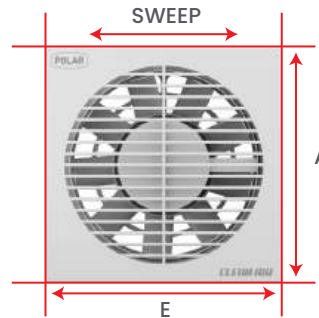

Clean Air Axial Flow Ventilating Fan - Detailed Chart

All sizes are in mm

Sweep	A	B	C	D	E
100	152	110	90	12	152
150	180	148	90	12	180
200	222	185	108	12	222

CLEAN AIR PASSION-VH

Installation & Maintenance Instructions

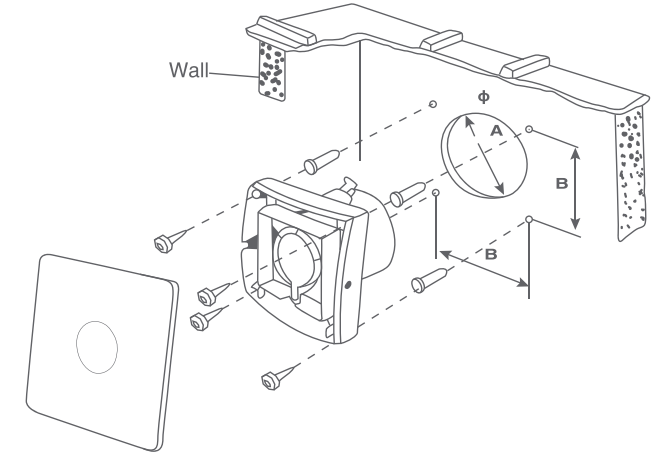

All sizes are in mm

Sweep	A	B
100	110	115
150	150	146
200	185	180

Wiring Instruction & Diagram

Connect Black & Red Wires to Supply
230 V, AC, 50 Hz, 1-Ph

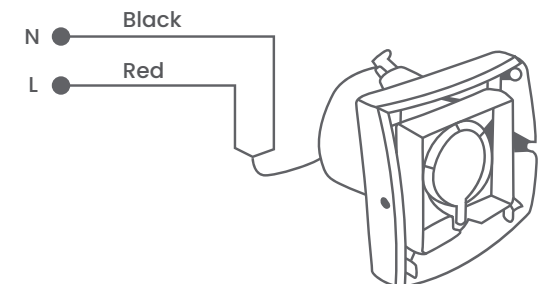

GENERAL GUIDELINES FOR SELECTION OF CEILING FANS & DOMESTIC EXHAUST FANS

Model Size	Sweep	Suitable for Room Size
Ceiling Fan	600 mm	For Small Shops, Cabins & Toilets
Ceiling Fan	900 mm	2.1 x 3 mtrs.
Ceiling Fan	1050 mm	3 x 3 mtrs.
Ceiling Fan	1200 mm	3.7 x 4 mtrs.
Ceiling Fan	1400 mm	4.3 x 5 mtrs.
Domestic Exhaust Fan	150/200 mm	2 x 2 x 2.8 mtrs.
Domestic Exhaust Fan	230 mm	2.4 x 2.4 x 2.8 mtrs.
Domestic Exhaust Fan	300 mm	3 x 2.4 x 2.8 mtrs.

FOR LARGE HALLS, AUDITORIUMS AND OFFICES, INSTALL TWO OR MORE CEILING FANS WITH A SPACING SPECIFIED BELOW

Sweep of Fan	Centre Distance
900 mm	2 mtrs.
1050 mm	2.1 mtrs.
1200 mm	2.4 mtrs.
1400 mm	3 mtrs.



Makes life easy

BRANCHES

SOUTH

Chennai | Madurai | Kochi | Bengaluru | Vijayawada | Hyderabad

EAST

Kolkata | Bhubaneswar | Guwahati | Patna | Ranchi

NORTH

Delhi NCR | Chandigarh | Jaipur | Kanpur | Ghaziabad | Dehradun | Varanasi

WEST & CENTRAL

Mumbai | Nagpur | Ahmedabad | Indore | Jabalpur | Raipur

POLAR ELEKTRIC LIMITED

CIN: U28199WB2004PLC100818
Regd. Off.: Unit No. 8B & 8C, 8th Floor
23 Circus Avenue, Kolkata 700 017
West Bengal, India

P: (033) 6629 1829

customercare@polarelektric.com
info@polarelektric.com
www.polarelektric.com
📍 PolarIndia



Customer Care
033 6100 6100

Note: The technical performance figures are rated values, based on a voltage range of 220-240V (230V rated), 50Hz, single phase, AC Supply. These are subject to manufacturing tolerance. Due to constant product upgradation, the models shown in the catalogue may undergo changes in features, performance or looks without prior notice. Model colours shown in the catalogue are indicative and may vary from the actual product colours. All ceiling fan models conform to IS:374-2019 and IS:302-2-80 safety norms, and all table, pedestal, and wall fans conform to IS:302-2-80 safety norms. The ceiling fans do not come with regulators.